

				<p>PALCO CONNECTOR</p> <p>22 GREAT HILL RD., NAUGATUCK, CT 06770</p> <p>UNLESS OTHERWISE SPECIFIED, PALCO WORKMANSHIP STANDARDS APPLY</p> <p>TOLERANCES ON: DECIMALS: XX ±.01 .XXX ±.005 ANGLES ±1/2° 32'</p> <p>DIMENSIONS IN INCHES OR (METRIC) DO NOT SCALE PRINTS</p>	DRAWN JEM	CHECKED JEM	ENGINEER JEM	APPROVED JEM	FSCM 58167
						DESCRIPTION TNC WATERPROOF FRONT MOUNT BULKHEAD JACK			
A	PER ECN 11592	02/20/13	JEM		DATE 12/3/12	DRAWING NO. 41-1969-0390	PLATING OPT. N		
REV.	DESCRIPTION	DATE	APPR.		CATALOG ITEM				

THE INFORMATION IN THIS DOCUMENT IS CONFIDENTIAL AND PROPRIETARY AND MAY NOT BE USED FOR ANY PURPOSE WITHOUT THE WRITTEN CONSENT OF PALCO.

CABLE ASSEMBLY PROCEDURE		PALEO CONNECTOR 22 GREAT HILL ROAD, NAUGATUCK, CT. 06770 PHONE: (203) 729-9090 FAX: (203) 723-1794	REV	DESCRIPTION	DATE	APPR
P/N	41-1969-0390		01	PRELIMINARY	12/5/12	JEM
PAGE 1 OF 1	DATE: 12/5/12		A	PER ECN 11592	02/20/13	JEM
DRAWN: JEM	APPROVED: JEM					
FOR USE WITH HIROSE 1.32mm CABLE						

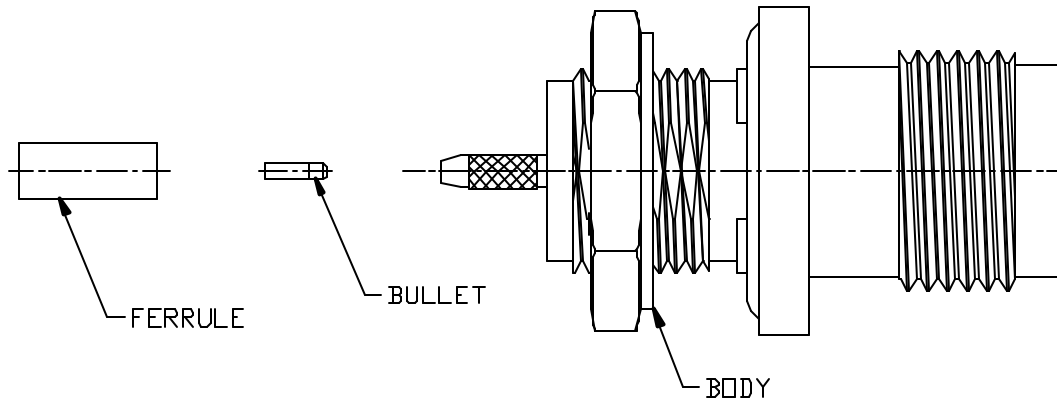

STEP 1
 TRIM CABLE TO DIMENSIONS
 SHOWN. TIN CENTER CONDUCTOR.
 CLEAN.

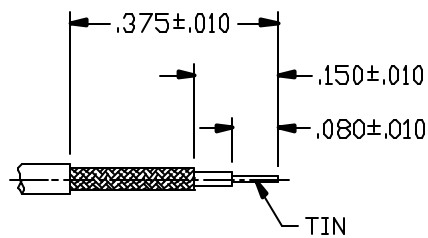

STEP 2
 SLIDE BULLET ONTO CENTER
 CONDUCTOR. SOLDER BULLET
 TO CENTER CONDUCTOR. CLEAN
 SOLDER JOINT.

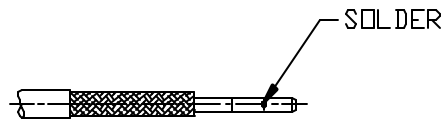

STEP 3
 SLIDE FERRULE ONTO CABLE.
 FLARE BRAID BY ROTATING
 CABLE DIELECTRIC.



STEP 4
 INSERT CABLE INTO BODY
 UNTIL CABLE BOTTOMS.
 SLIDE FERRULE UP UNTIL
 IT BOTTOM ON SHOULDER.
 CRIMP USING .081 HEX
 DIE (DANIELS Y1547P).

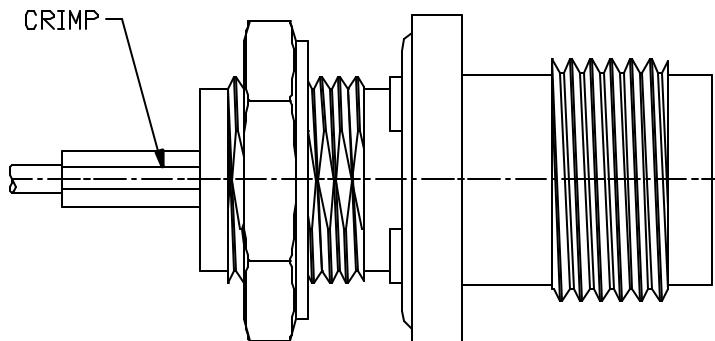

INTERFACE DESIGN STANDARD		 22 GREAT HILL ROAD, NAUGATUCK, CT. 06770 PHONE: (203) 729-9090 FAX: (203) 723-1794	REV	DESCRIPTION	DATE	APPR
IDS-41			A	PER ECN 5421	03/21/00	HN
PAGE 1 OF 3	DATE: 02/28/94		B	PER ECN 7427	05/07/04	JM
DRAWN: EK	APPROVED: JEM		C	PER ECN 9024	08/06/07	JEM
		D	PER ECN 10095	11/30/09	JEM	

DESCRIPTION: TNC SERIES

MECHANICAL

MATERIALS

BODIES, FITTINGS, MALE CONTACTS - BRASS PER ASTM-B-16.
 INSULATORS - TEFLON (PTFE) PER ASTM-D-1457.
 CONTACTS, FEMALE AND OUTER - BERYLLIUM COPPER PER ASTM-B-196.
 GASKETS - SILICONE RUBBER PER ZZ-R-765.

FINISHES (ADD LETTER TO END OF PART NUMBER)

BODIES, OUTER CONTACTS, FITTINGS - SILVER PER QQ-S-365 (S SUFFIX)
 NICKEL - PER QQ-N-290 (N SUFFIX)
 CONTACTS - GOLD PLATED .000050 MIN. PER MIL-G-45204 OVER
 .00010 MIN. OF COPPER PER MIL-C-14550.
 OTHER METAL PARTS - SILVER OR NICKEL PLATED TO MEET THE ENVIRONMENTAL
 REQUIREMENTS.

MATING CHARACTERISTICS

PER MIL-C-39012.
 FORCE TO ENGAGE /DISENGAGE- TORQUE - 2 IN-LBS. MAX.
 COUPLING NUT RETENTION - AXIAL FORCE 100 LBS. MIN.,
 TORQUE - 15 IN-LBS. MIN.
 DURABILITY: 500 CYCLES PER MIL-C-39012.

ELECTRICALS

IMPEDANCE: 50 OHMS.
 FREQUENCY RANGE: DC TO 11 GHz (CONNECTOR PERFORMANCE ONLY;
 DEPENDENT OF CABLE).
 INSULATION RESISTANCE: 5000 MEGOHMS, MIN..
 TEMPERATURE RATING: -65°C TO +165°C.
 DWV: 1500 VOLTS AT SEA LEVEL.
 CONTACT RESISTANCE: CENTER CONTACT - 1.5 MILLIOHMS;
 OUTER CONTACT - 0.2 MILLIOHMS.
 VSWR: 1.30 MAX.
 R.F. LEAKAGE: -60 dB MIN. FROM 2 TO 3 GHz.
 INSERTION LOSS: 0.18 dB MAX. AT 9 GHz.

ENVIRONMENTAL

VIBRATION: MIL-STD-202, METHOD 204, TEST CONDITION B.
 SHOCK: MIL-STD-202, METHOD 213, TEST CONDITION B.
 THERMAL SHOCK: MIL-STD-202, METHOD 107, TEST CONDITION B @ 85°C.
 CORROSION: MIL-STD-202, METHOD 101, TEST CONDITION B.
 MOISTURE RESISTANCE: MIL-STD-202, METHOD 106,
 NO MEASUREMENT AT HIGH HUMIDITY.

REV	DESCRIPTION	DATE	APPR
A	PER ECN 5421	03/21/00	HN
B	PER ECN 7427	05/07/04	JM
C	PER ECN 9024	08/06/07	JEM
D	PER ECN 10095	11/30/09	JEM

DESCRIPTION: TNC SERIES

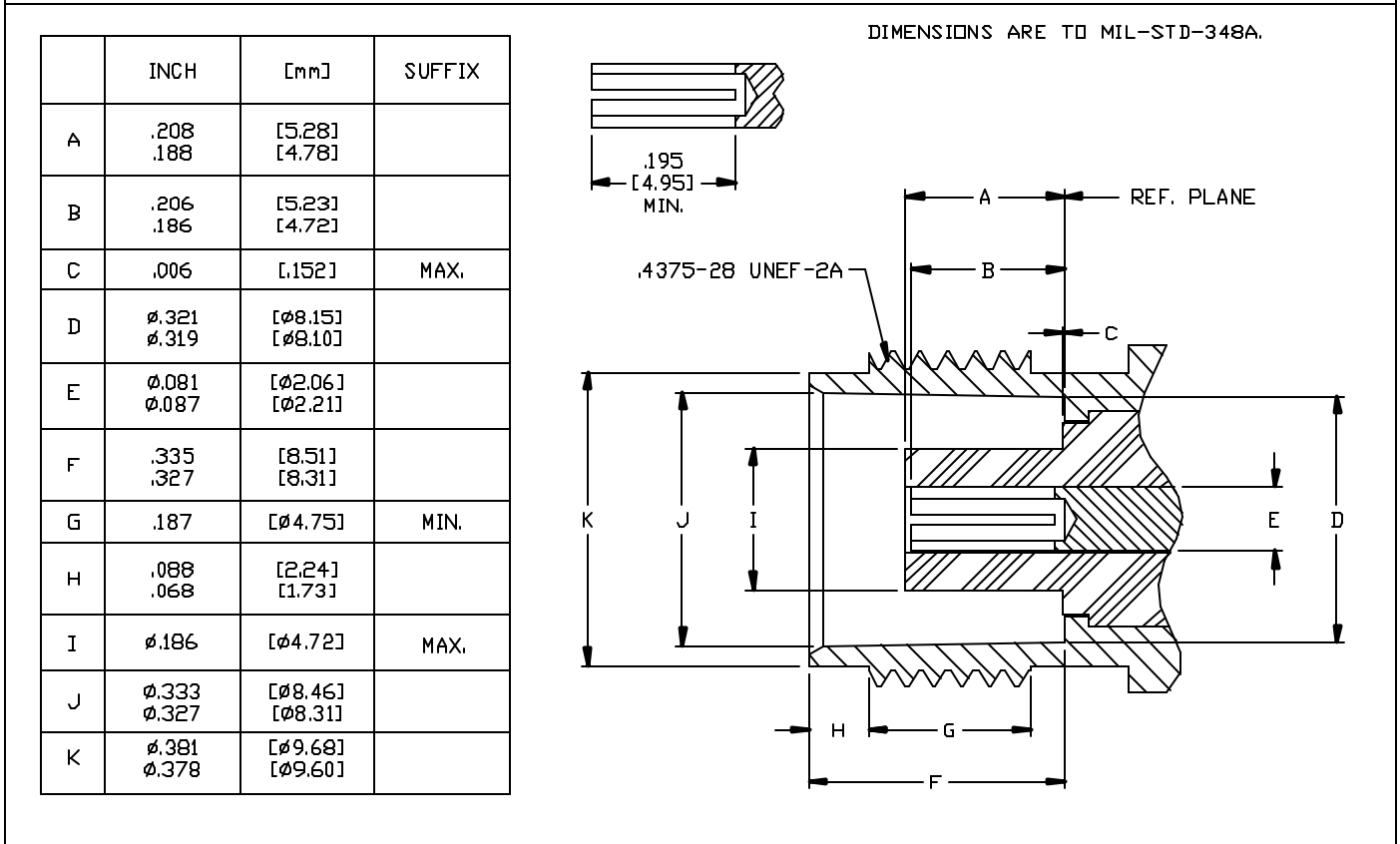
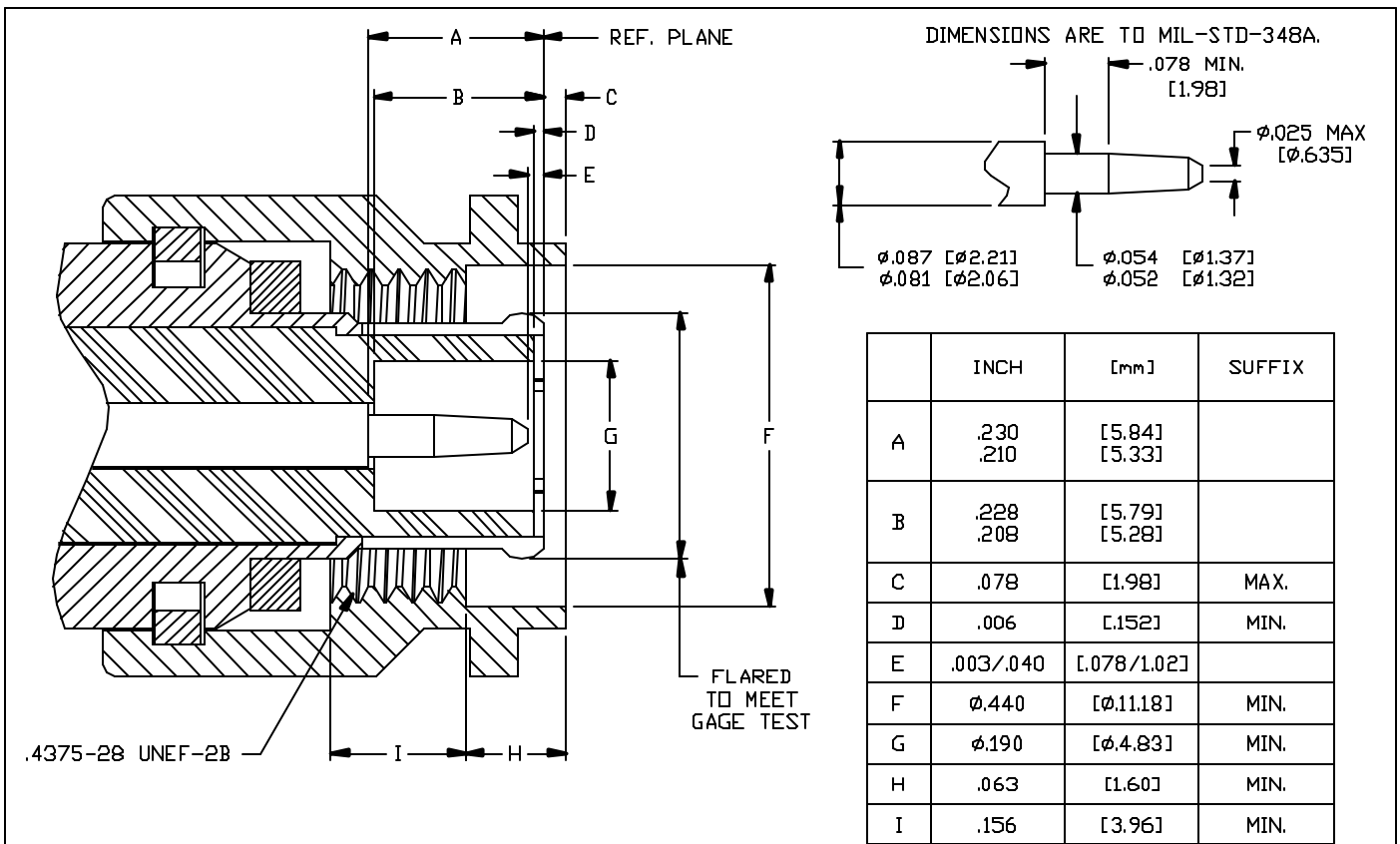

INTERFACE DESIGN STANDARD		PALEO CONNECTOR 22 GREAT HILL ROAD, NAUGATUCK, CT. 06770 PHONE: (203) 729-9090 FAX: (203) 723-1794	REV	DESCRIPTION	DATE	APPR
IDS-41			A	PER ECN 5421	03/21/00	HN
PAGE 3 OF 3	DATE: 02/28/94		B	PER ECN 7427	05/07/04	JM
DRAWN: JEM	APPROVED: HN		C	PER ECN 9024	08/06/07	JEM
		D	PER ECN 10095	11/30/09	JEM	

DESCRIPTION: TNC SERIES

DIMENSIONS ARE TO MIL-STD-348A.

