

CAD DRAWING – NO MANUAL REVISIONS

REV	DESCRIPTION	MM/DD/YY	ZONE
A	RELEASED	04/01/09	
B	ECR1007100	07/06/10	A8,C3

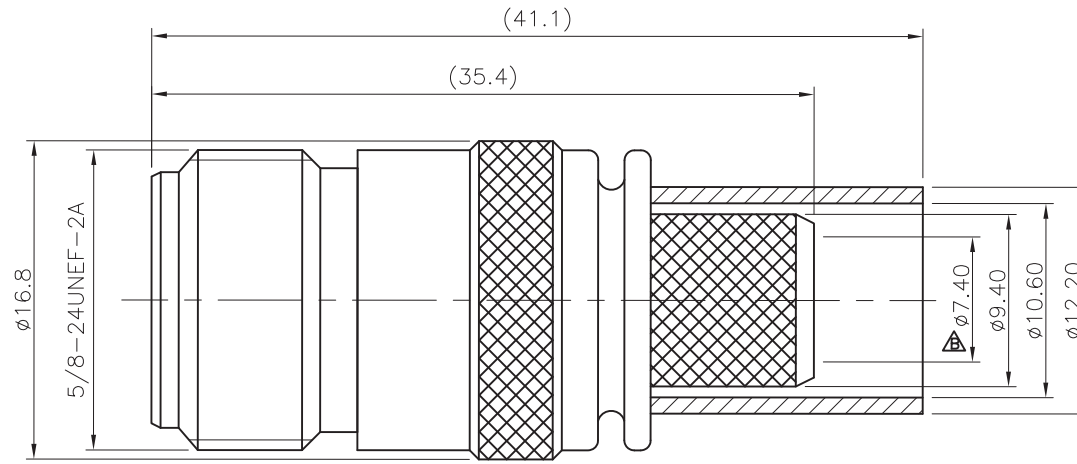

NOTES

- 1.DESIGN AND INTERFACE PER I.D.S.-550.
- 2.FOR USE WITH LMR400 OR SIMILAR CABLE.
- 3.DUST CAP MUST BE ATTACHED.
- 4.ALL MATERIALS AND FINISHES MUST BE ROHS COMPLIANT.

THESE ITEM(S)/TECHNICAL DATA ARE CONTROLLED FOR EXPORT FROM THE UNITED STATES IN ACCORDANCE WITH THE US EXPORT ADMINISTRATION REGULATIONS (EAR). DIVERSION CONTRARY TO U.S. LAW PROHIBITED.

4	FERRULE	COPPER			1
3	INSULATOR	PTFE			1
2	CENTER CONTACT	TIN BRONZE			1
1	BODY	BRASS			1
ITEM NO.	PART DESCRIPTION	MATERIAL			QTY



SHANGHAI PHOENIX COMMUNICATION & TECHNOLOGY COMPANY LTD.  
SHANGHAI, CHINA.

UNLESS OTHERWISE SPECIFIED, PHOENIX WORKMANSHIP STANDARDS APPLY  
TOLERANCES ON: DECIMALS: .X ±0.25 .XX ±0.13 ANGLES ±3°  
DIMENSIONS IN METRIC DO NOT SCALE PRINTS  
UNLESS OTHERWISE SPECIFIED DIMENSIONS ARE IN MILLIMETER

DESCRIPTION  
N FEMALE STRAIGHT FOR LMR400;NON-MAGNETIC

DRAWN: ZHANGWEILI	DWG NO. 55017003201	PLT.OPT. S
CHECKED: KGU		
APPROVED: MYE		SHEET 1 OF 1

INTERFACE DESIGN STANDARD	
IDS-550	
DATE: 02/08/03	
DRAWN: EK	APPROVED: HN

**PALEO**  
**CONNECTOR**

22 GREAT HILL ROAD, NAUGATUCK, CT. 06770  
PHONE: (203) 729-9090 FAX: (203) 723-1794

REV	DESCRIPTION	DATE	APPR
A	PER ECN 6986	02/28/03	HN

DESCRIPTION: N 550 SERIES

