

THESE ITEM(S)/TECHNICAL DATA ARE CONTROLLED FOR EXPORT FROM THE UNITED STATES IN ACCORDANCE WITH THE US EXPORT ADMINISTRATION REGULATIONS (EAR). DIVERSION CONTRARY TO U.S. LAW PROHIBITED.

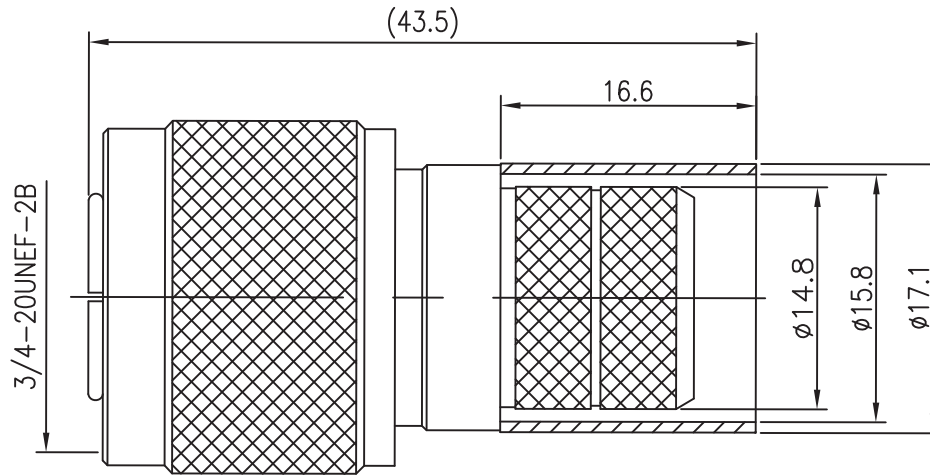

NOTES:

1. DESIGN AND INTERFACE PER I.D.S-55  $\triangle$
2. FOR USE WITH LMR 600 CABLE
3. ALL MATERIALS AND FINISHES MUST BE RoHS COMPLIANT.

ITEM NO.	PART DESCRIPTION	MATERIAL	QTY	UNIT
7	RETAINING RING	TIN BRONZE	1	PCS
6	COUPLING NUT	BRASS	1	PCS
5	GASKET	SILICONE RUBBER	1	PCS
4	INSULATOR	PTFE	1	PCS
3	BODY	BRASS	1	PCS
2	CENTER CONTACT	BRASS	1	PCS
1	FERRULE	COPPER	1	PCS



The PHOENIX Company of Chicago <sup>TM</sup>

DESCRIPTION:

HN STR PLUG FOR LMR 600, NO-MAGNETIC

DRAWN: STEVEN YOU

DWG NO.

PLT.OPT.

59907003802

E

CHECKED: EILEEN ZHU

APPROVED: MAX WANG



SHEET 1 OF 1

UNLESS OTHERWISE SPECIFIED, PHOENIX WORKMANSHIP STANDARDS APPLY 32  
 TOLERANCES ON: DECIMALS: .X ±0.25 .XX ±0.13 ANGLES ±3° DIMENSIONS IN METRIC DO NOT SCALE PRINTS  
 UNLESS OTHERWISE SPECIFIED DIMENSIONS ARE IN MILLIMETER

REV	DESCRIPTION	DATE	APPR
A	PER ECN 7696	11/08/04	JM

DESCRIPTION: HN SERIES

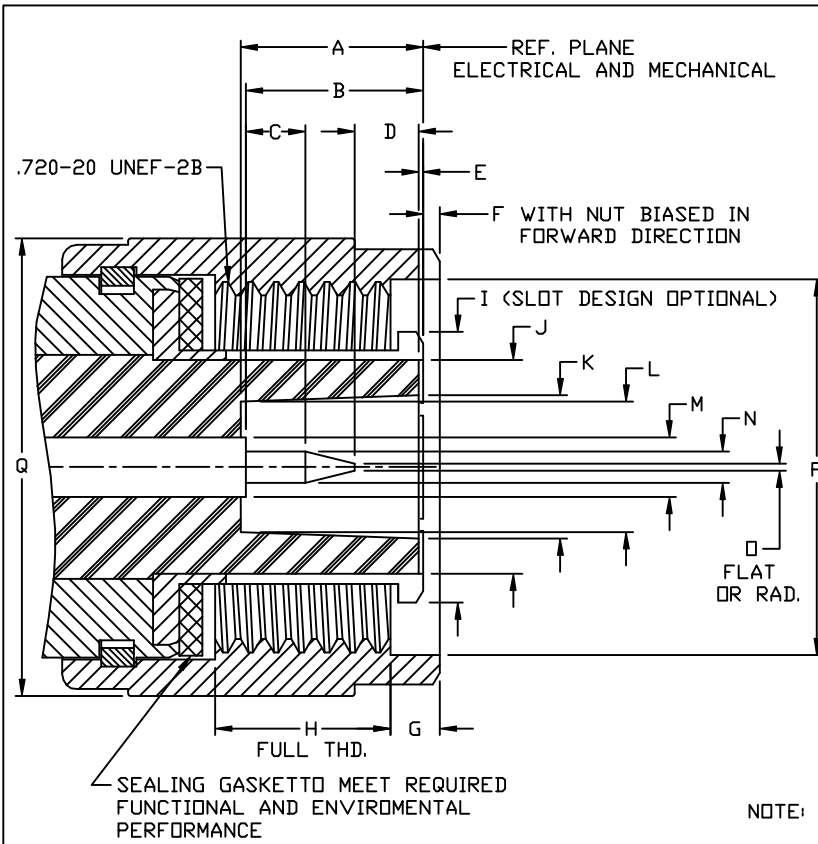

DIMENSIONS ARE TO MIL-STD-348A.

	INCH	[mm]	SUFFIX
A	.368	[9.35]	MIN.
B	.388 .358	[9.86] [9.09]	
C	.120	[3.05]	MIN.
D	.138	[3.51]	MIN.
E	.005	[.13]	MIN.
F	.058	[1.47]	MAX.
G	.100	[2.54]	MIN.
H	.403	[10.24]	MIN.
I	FLARE TO MEET GAGE TEST		
J	SEE NOTE		
K	∅.289	[7.34]	MIN.
L	∅.263	[6.68]	MIN.
M	∅.132	[3.35]	MAX.
N	∅.066 ∅.062	[1.68] [1.57]	
∅	∅.015	[.38]	MAX.
P	∅.760	[9.30]	MIN.
Q	∅.925	[23.50]	MAX.

NOTE: I.D. OF OUTER CONTACT WHEN INSERTED INTO A .548 MAX. DIA. RING GAUGE SHALL BE .432 MIN.

DIMENSIONS ARE TO MIL-STD-348A.

	INCH	[mm]	SUFFIX
A	.590	[14.99]	MIN.
B	.522 .516	[13.26] [13.11]	
C	.368	[9.35]	MAX.
D	.358 .328	[9.09] [8.33]	
E	.005	[.13]	MAX.
F	.359	[9.12]	MIN.
G	.087 .077	[2.21] [1.96]	
H	.355	[9.02]	MIN.
I	I.D. TO MEET PERFORMANCE REQUIREMENTS WHEN MATED WITH .062/.066 DIA. PIN		
J	∅.268	[6.81]	MAX.
K	∅.294	[7.47]	MAX.
L	∅.430	[10.92]	MAX.
M	∅.553 ∅.548	[14.05] [13.92]	
N	∅.578 ∅.571	[14.68] [14.50]	
∅	∅.683 ∅.662	[17.35] [16.81]	
P	∅.132	[3.35]	MAX.
Q	∅.755	[19.18]	MAX.

