

4

3

2

1

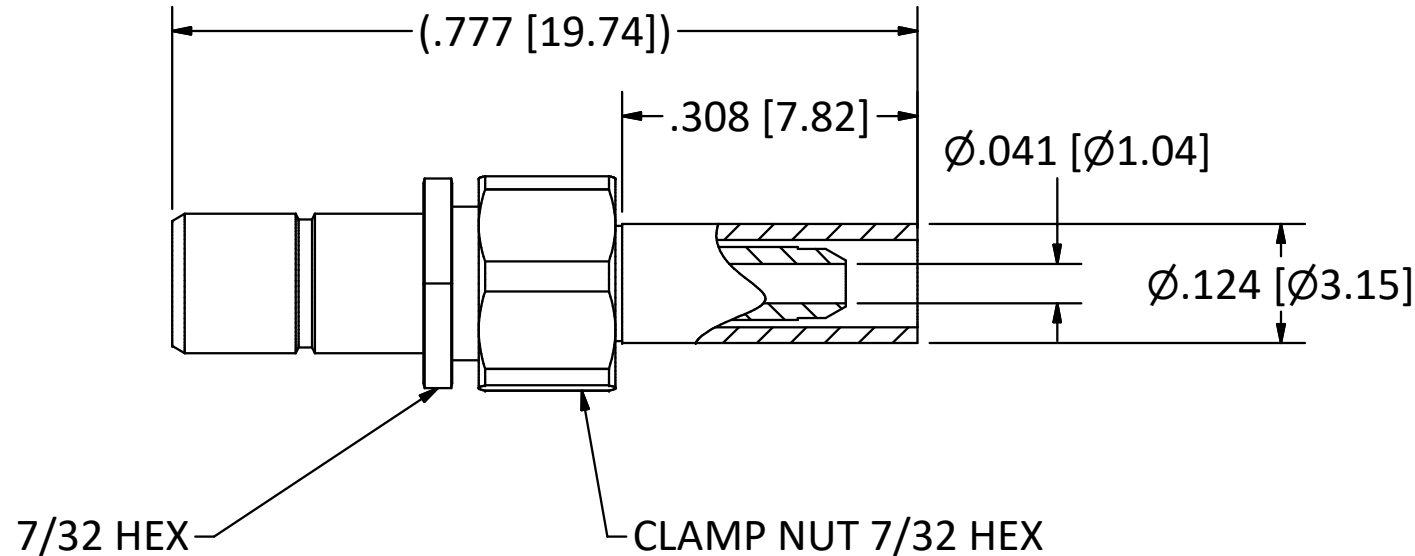
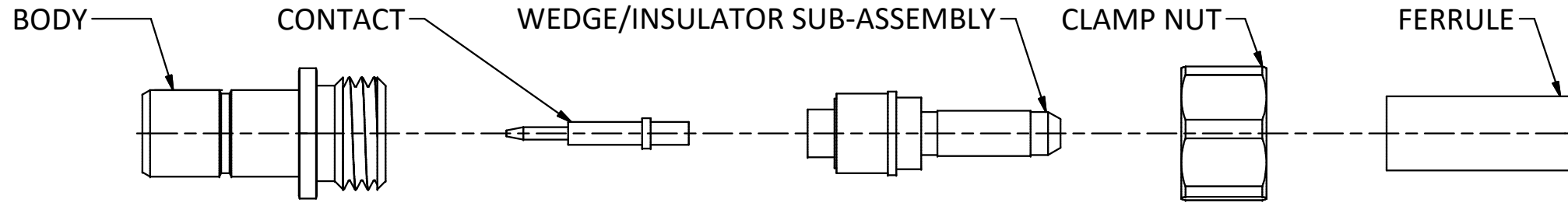

NOTES:

- 1. SPECIFICATIONS PER IDS-09J.
- 2. CLAMP NUT, CONTACT, FERRULE, AND WEDGE/INSULATOR SUB-ASSEMBLY SHIPPED LOOSE.
- 3. ACCOMMODATES RG-178 OR RG-196 CABLE.
- 4. CRIMP WITH .105 HEX DIE (M22520/5-03).
- 5. MAGNETISM: <1.00000 mu.

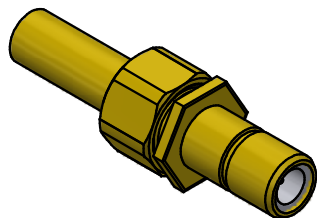

SCALE 2.5 : 1

<p>This drawing embodies a proprietary design of The Phoenix Company of Chicago, Inc., Naugatuck, CT 06770. All design, manufacturing, reproduction, use, sale, and other rights regarding the same are expressly reserved. The information in this drawing may be covered completely or in part by patents and/or patents pending.</p>				<p>WARNING - THIS DOCUMENT CONTAINS TECHNICAL DATA WHOSE EXPORT IS RESTRICTED BY THE ARMS EXPORT CONTROL ACT (TITLE 22, U.S.C., SEC 2751, ET. SEQ.) OR THE EXPORT ADMINISTRATION ACT OF 1979, AS AMENDED, TITLE 50, U.S.C., APP 2401 ET SEQ. VIOLATIONS OF THESE EXPORT LAWS ARE SUBJECT TO SEVERE CRIMINAL PENALTIES. DISSEMINATE IN ACCORDANCE WITH PROVISIONS OF DOD DIRECTIVE 5230.25.</p>			<p>Filename: ver2\Autodesk Inventor Data Base\Assemblies\09 Series\09-1800-0400J-CU.idw</p>			<p>The PHOENIX Company of Chicago, Inc. 22 GREAT HILL RD., NAUGATUCK, CT 06770 WWW.PHOENIXOFCHICAGO.COM PHONE: (800) 323-9562 FAX:(630) 206-1801</p>																								
							<p>UNLESS OTHERWISE SPECIFIED, PHOENIX WORKMANSHIP STANDARDS APPLY DIMENSIONS IN INCHES OR (METRIC)</p> <p>DO NOT SCALE PRINTS</p> <p>TOLERANCES ARE: FRACTIONS: ± 1/64 DECIMALS: .XX ± .01 .XXX ± .003 ANGLES: ± 1/2°</p>		<table border="1"> <tr><th>APPROVALS</th><th>DATE</th></tr> <tr><td>DRAWN YT</td><td>12/21/2011</td></tr> <tr><td>CHECKED JM</td><td>12/21/2011</td></tr> <tr><td>QA</td><td></td></tr> <tr><td>MFG</td><td></td></tr> <tr><td>ENGINEER JV</td><td>12/21/2011</td></tr> <tr><td>APPROVED PP</td><td>12/21/2011</td></tr> </table>				APPROVALS	DATE	DRAWN YT	12/21/2011	CHECKED JM	12/21/2011	QA		MFG		ENGINEER JV	12/21/2011	APPROVED PP	12/21/2011	<p>TITLE</p> <p>SMB JACK, CRIMP/CLAMP TERMINATION</p>							
APPROVALS	DATE																																	
DRAWN YT	12/21/2011																																	
CHECKED JM	12/21/2011																																	
QA																																		
MFG																																		
ENGINEER JV	12/21/2011																																	
APPROVED PP	12/21/2011																																	
<table border="1"> <tr><th>REV.</th><th>DESCRIPTION</th><th>DATE</th><th>BY</th></tr> <tr><td>A</td><td>PER ECN 11201</td><td>12/21/11</td><td>JEM</td></tr> </table>		REV.	DESCRIPTION	DATE	BY	A	PER ECN 11201	12/21/11	JEM	<p>File Name: ver2\Autodesk Inventor Data Base\Assemblies\09 Series\09-1800-0400J-CU.idw</p>		<table border="1"> <tr><th>SIZE</th><th>FSCM</th><th>DWG NO</th><th>REV</th><th>PLATING OPT.</th></tr> <tr><td>B</td><td>58167</td><td>09-1800-0400J</td><td>A</td><td></td></tr> </table>		SIZE	FSCM	DWG NO	REV	PLATING OPT.	B	58167	09-1800-0400J	A		<table border="1"> <tr><th>SCALE</th><th>F.S.R. #</th><th>SHEET</th><th>OF</th></tr> <tr><td>5 : 1</td><td></td><td>1</td><td>1</td></tr> </table>			SCALE	F.S.R. #	SHEET	OF	5 : 1		1	1
REV.	DESCRIPTION	DATE	BY																															
A	PER ECN 11201	12/21/11	JEM																															
SIZE	FSCM	DWG NO	REV	PLATING OPT.																														
B	58167	09-1800-0400J	A																															
SCALE	F.S.R. #	SHEET	OF																															
5 : 1		1	1																															

4

3

2

1