

CABLE ASSEMBLY PROCEDURE		 22 GREAT HILL ROAD, NAUGATUCK, CT. 06770 PHONE: (203) 729-9090 FAX: (203) 723-1794	REV	DESCRIPTION	DATE	APPR
P/N	10-2800-0400		C	REL. ECN 5228	09/03/99	HN
PAGE 1 OF 1	DATE: 09/03/99		D	PER ECN 7263	01/26/04	HN
DRAWN: KJT	APPROVED: HN					
FOR USE WITH RG-179 CABLE						

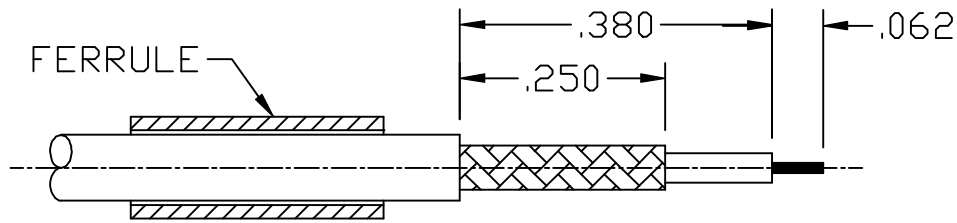

STEP 1:  
 TRIM CABLE TO DIMENSIONS SHOWN. TIN CENTER CONDUCTOR.  
 SLIDE FERRULE OVER CABLE.

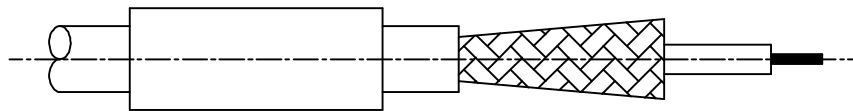

STEP 2:  
 FLARE BRAID BY ROTATING DIELECTRIC.

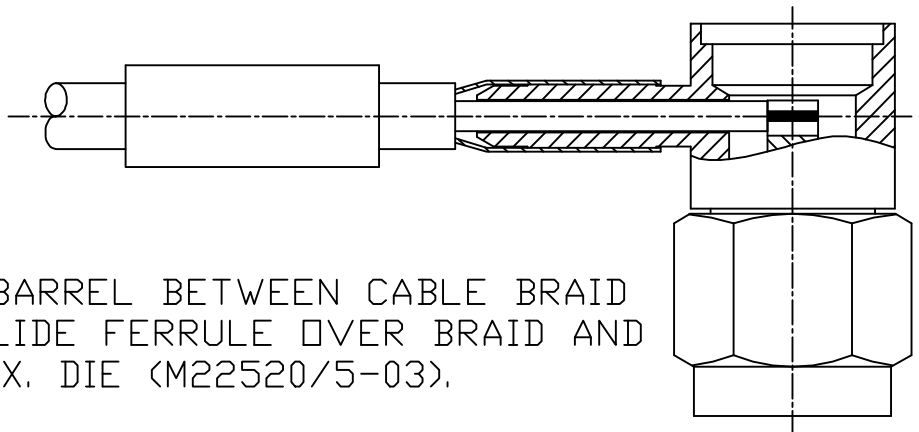

STEP 3:  
 INSERT CONNECTOR BARREL BETWEEN CABLE BRAID  
 AND DIELECTRIC. SLIDE FERRULE OVER BRAID AND  
 CRIMP USING .105 HEX. DIE (M22520/5-03).

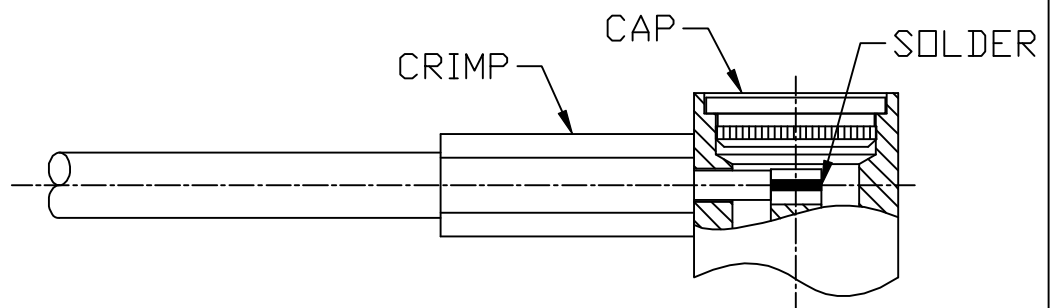

STEP 4:  
 SOLDER CENTER CONDUCTOR TO CENTER CONTACT.  
 PRESS CAP INTO HOLE.