

4

3

2

1

B

B

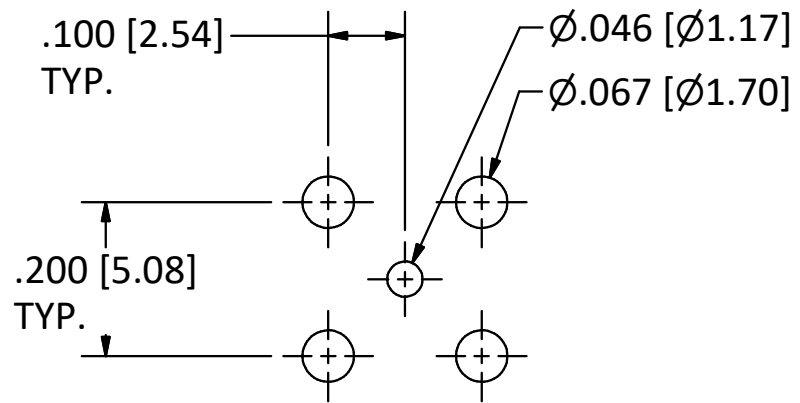

RECOMMENDED MOUNTING HOLES

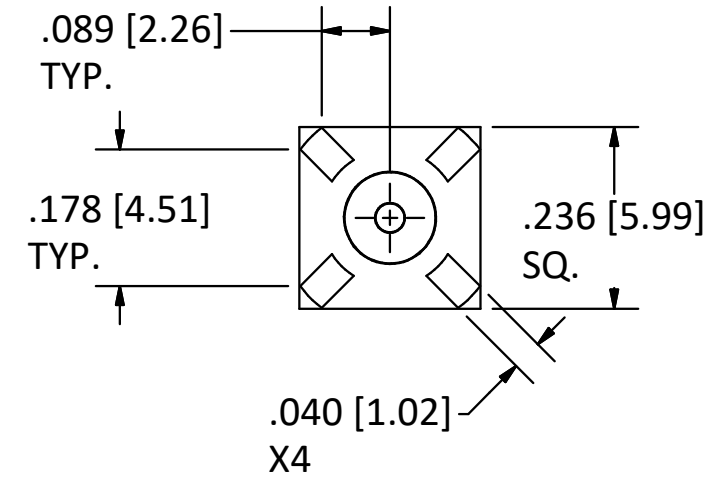
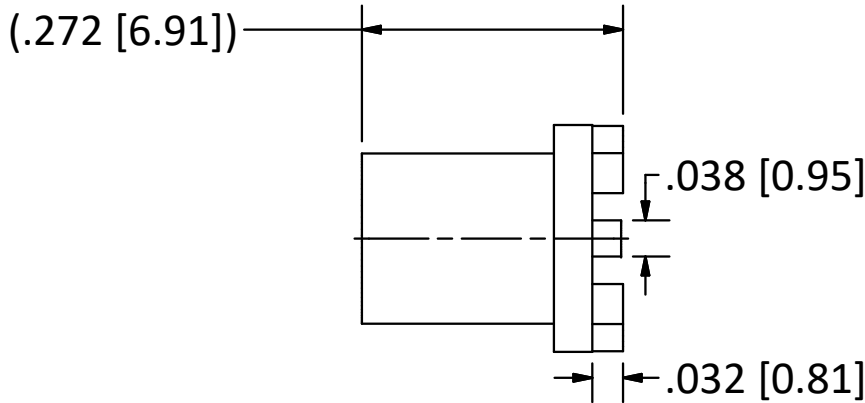

- NOTES:
 1. SPECIFICATIONS PER IDS-13J.
 2. MAGNETISM: <1.00000 mu.

A

A



SCALE 2.5: 1

REV.	DESCRIPTION	DATE	BY
J	PER ECN 13685	2/18/20	JEM
H	PER ECN 10479	7/23/10	JEM
G	PER ECN 6803	11/8/02	HN
F	PER ECN 4260	1/5/98	HN
E	PER ECN 3211	11/7/95	HN

This drawing embodies a proprietary design of The Phoenix Company of Chicago, Inc., Naugatuck, CT 06770. All design, manufacturing, reproduction, use, sale, and other rights regarding the same are expressly reserved. The information in this drawing may be covered completely or in part by patents and/or patents pending.

WARNING - THIS DOCUMENT CONTAINS TECHNICAL DATA WHOSE EXPORT IS RESTRICTED BY THE ARMS EXPORT CONTROL ACT (TITLE 22, U.S.C., SEC 2751, ET. SEQ.) OR THE EXPORT ADMINISTRATION ACT OF 1979, AS AMENDED, TITLE 50, U.S.C., APP 2401 ET SEQ. VIOLATIONS OF THESE EXPORT LAWS ARE SUBJECT TO SEVERE CRIMINAL PENALTIES. DISSEMINATE IN ACCORDANCE WITH PROVISIONS OF DOD DIRECTIVE 5230.25.

Filename: ver2\Autodesk Inventor Data Base\Assemblies\13 Series\13-1449-00J-CU.idw		
UNLESS OTHERWISE SPECIFIED, PHOENIX WORKMANSHIP STANDARDS APPLY DIMENSIONS IN INCHES OR (METRIC) DO NOT SCALE PRINTS TOLERANCES ARE: FRACTIONS: ± 1/64 DECIMALS: .XX ± .01 .XXX ± .003 ANGLES: ± 1/2°	APPROVALS	DATE
	DRAWN EK	5/5/1993
	CHECKED HN	5/5/1993
	QA	
	MFG	
	ENGINEER LB	5/3/1993
APPROVED HN	5/5/1993	

The PHOENIX Company of Chicago, Inc.
 22 GREAT HILL RD., NAUGATUCK, CT 06770
 WWW.PHOENIXOFCHICAGO.COM
 PHONE: (800) 323-9562 FAX:(630) 206-1801

TITLE
MCX STRAIGHT JACK, PRINTED CIRCUIT MOUNT

SIZE B	FSCM 58167	DWG NO 13-1449-00J	REV J	PLATING OPT.
SCALE 5 : 1	F.S.R. #	SHEET 1	OF 1	

4

3

2

1