

| | | | | | | |
|--------------------------|----------------|---|-----|---------------|----------|------|
| CABLE ASSEMBLY PROCEDURE | | PALEO CONNECTOR 22 GREAT HILL ROAD, NAUGATUCK, CT. 06770 PHONE: (203) 729-9090 FAX: (203) 723-1794 | REV | DESCRIPTION | DATE | APPR |
| P/N | 15-0020-0003 | | F | PER ECN 5273 | 10/25/99 | HN |
| PAGE 1 OF 1 | DATE: 10/12/99 | | G | PER ECN 5356 | 01/31/00 | HN |
| DRAWN: MY | APPROVED: HN | | H | PER ECN 7214 | 11/25/03 | HN |
| FOR USE #16 AWG WIRE | | | K | PER ECN 10507 | 08/13/10 | JEM |

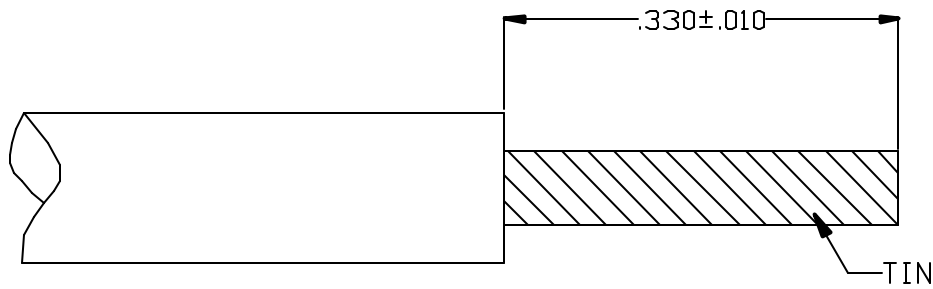

STEP 1

TRIM WIRE TO DIMENSIONS SHOWN.
TIN CENTER CONDUCTOR.

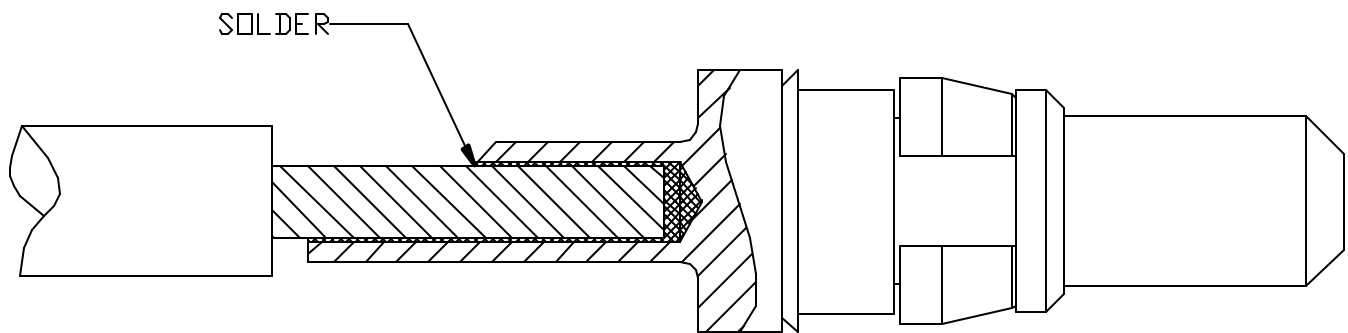

STEP 2

SOLDER WIRE TO THE BODY AS SHOWN.
CLEAN AND INSPECT SOLDER JOINT.