

4

3

2

1

FERRULE

BODY

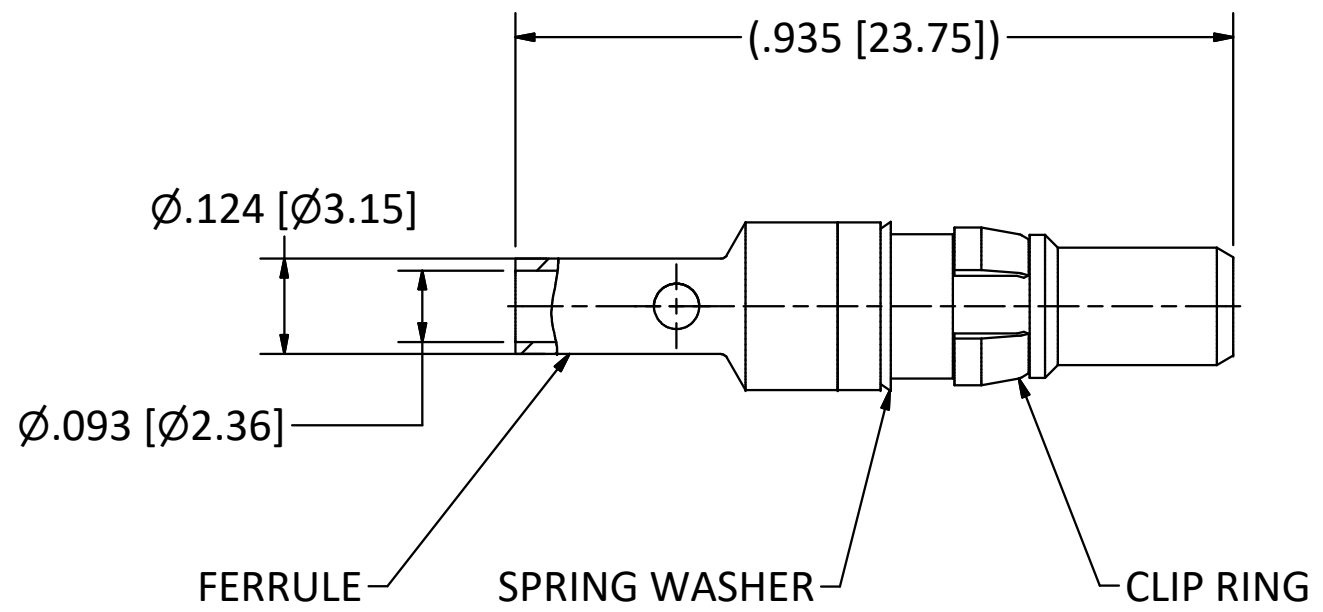
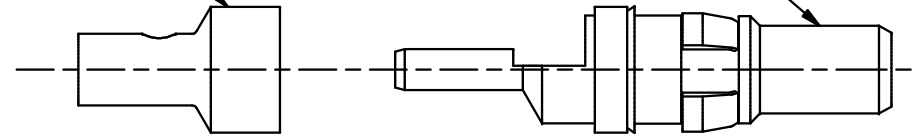

- NOTES:
1. SPECIFICATIONS PER IDS-15J.
 2. FERRULE SHIPPED LOOSE.
 3. ACCOMMODATES RG-178 OR RG-196 CABLES.
 4. MAGNETISM: <1.00000 mu.
- HOUSING:** D-SUBMINIATURE, SIZE 8 CAVITY.

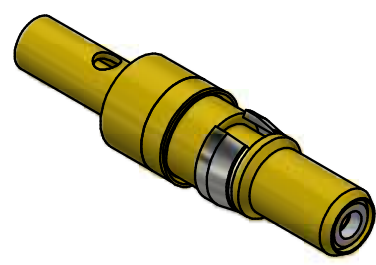

SCALE 2.5 : 1

This drawing embodies a proprietary design of The Phoenix Company of Chicago, Inc., Naugatuck, CT 06770. All design, manufacturing, reproduction, use, sale, and other rights regarding the same are expressly reserved. The information in this drawing may be covered completely or in part by patents and/or patents pending.				WARNING - THIS DOCUMENT CONTAINS TECHNICAL DATA WHOSE EXPORT IS RESTRICTED BY THE ARMS EXPORT CONTROL ACT (TITLE 22, U.S.C., SEC 2751, ET. SEQ.) OR THE EXPORT ADMINISTRATION ACT OF 1979, AS AMENDED, TITLE 50, U.S.C., APP 2401 ET SEQ. VIOLATIONS OF THESE EXPORT LAWS ARE SUBJECT TO SEVERE CRIMINAL PENALTIES. DISSEMINATE IN ACCORDANCE WITH PROVISIONS OF DOD DIRECTIVE 5230.25.		Filename: ver2\Autodesk Inventor Data Base\Assemblies\15 Series\15-0020-0400J-CU.idw		The PHOENIX Company of Chicago, Inc. 22 GREAT HILL RD., NAUGATUCK, CT 06770 WWW.PHOENIXOFCHICAGO.COM PHONE: (800) 323-9562 FAX:(630) 206-1801																			
						UNLESS OTHERWISE SPECIFIED, PHOENIX WORKMANSHIP STANDARDS APPLY DIMENSIONS IN INCHES OR (METRIC) DO NOT SCALE PRINTS TOLERANCES ARE: FRACTIONS: $\pm 1/64$ DECIMALS: $.XX \pm .01$ $.XXX \pm .003$ ANGLES: $\pm 1/2^\circ$		<table border="1"> <thead> <tr> <th>APPROVALS</th> <th>DATE</th> </tr> </thead> <tbody> <tr> <td>DRAWN CA</td> <td>1/3/2020</td> </tr> <tr> <td>CHECKED JEM</td> <td>1/3/2020</td> </tr> <tr> <td>QA</td> <td></td> </tr> <tr> <td>MFG</td> <td></td> </tr> <tr> <td>ENGINEER CA</td> <td>1/3/2020</td> </tr> <tr> <td>APPROVED JEM</td> <td>1/3/2020</td> </tr> </tbody> </table>		APPROVALS	DATE	DRAWN CA	1/3/2020	CHECKED JEM	1/3/2020	QA		MFG		ENGINEER CA	1/3/2020	APPROVED JEM	1/3/2020	TITLE PDM PLUG, DIRECT SOLDER TERMINATION			
APPROVALS	DATE																										
DRAWN CA	1/3/2020																										
CHECKED JEM	1/3/2020																										
QA																											
MFG																											
ENGINEER CA	1/3/2020																										
APPROVED JEM	1/3/2020																										
<table border="1"> <thead> <tr> <th>REV.</th> <th>DESCRIPTION</th> <th>DATE</th> <th>BY</th> </tr> </thead> <tbody> <tr> <td>J</td> <td>ECN 13625</td> <td>1/3/20</td> <td>JEM</td> </tr> <tr> <td>H</td> <td>ECN 12608</td> <td>8/27/17</td> <td>JEM</td> </tr> <tr> <td>G</td> <td>ECN 6823</td> <td>12/12/02</td> <td>HN</td> </tr> </tbody> </table>		REV.	DESCRIPTION	DATE	BY	J	ECN 13625	1/3/20	JEM	H	ECN 12608	8/27/17	JEM	G	ECN 6823	12/12/02	HN	SIZE B FSCM 58167		DWG NO 15-0020-0400J		REV J PLATING OPT. J		SCALE 4 : 1 F.S.R. #		SHEET 1 OF 1	
REV.	DESCRIPTION	DATE	BY																								
J	ECN 13625	1/3/20	JEM																								
H	ECN 12608	8/27/17	JEM																								
G	ECN 6823	12/12/02	HN																								

4

3

2

1