

| | | | | | | |
|----------------------------|----------------|---|-----|---------------|----------|------|
| CABLE ASSEMBLY PROCEDURE | | PALEO CONNECTOR 22 GREAT HILL ROAD, NAUGATUCK, CT. 06770 PHONE: (203) 729-9090 FAX: (203) 723-1794 | REV | DESCRIPTION | DATE | APPR |
| P/N | 15-0020-0860 | | A | PER ECN 3886 | 05/08/97 | HN |
| PAGE 1 OF 2 | DATE: 05/08/97 | | D | PER ECN 7475 | 06/14/04 | JEM |
| DRAWN: EY | APPROVED: HN | | E | PER ECN 10509 | 08/13/10 | JEM |
| FOR RG-405 (M17/133) CABLE | | | | | | |

FOR USE WITH RG-405 S/R CABLE

STEP 1

TRIM CABLE TO DIMENSIONS SHOWN
TIN CENTER CONDUCTOR.

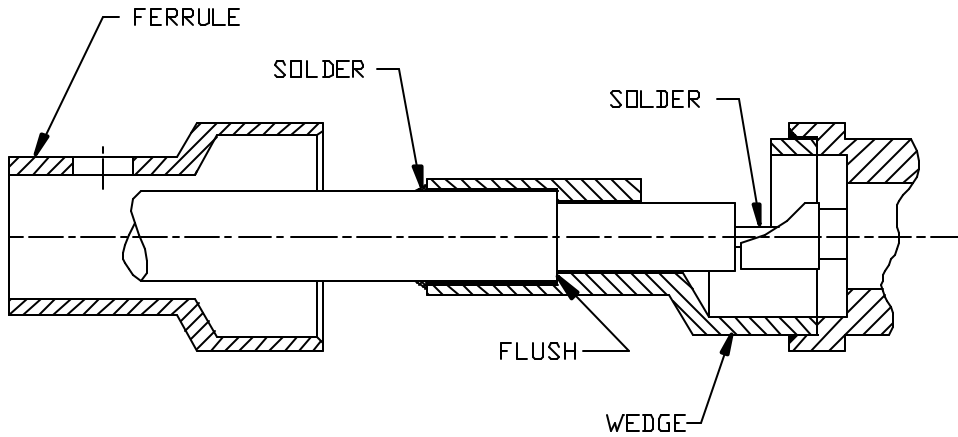
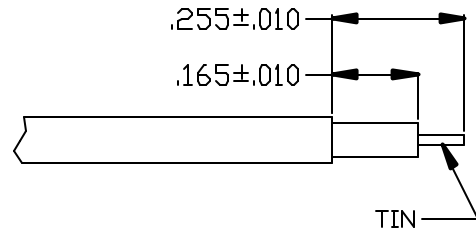

STEP 2

SLIDE FERRULE OVER CABLE.
INSERT CABLE INTO WEDGE UNTIL OUTER CONDUCTOR IS FLUSH
WITH INSIDE DIAMETER OF WEDGE. CENTER CONDUCTOR
MUST PROTRUDE INTO CONTACT. SOLDER CENTER
CONDUCTOR INTO CONTACT AND OUTER CONDUCTOR
INTO WEDGE. CLEAN.

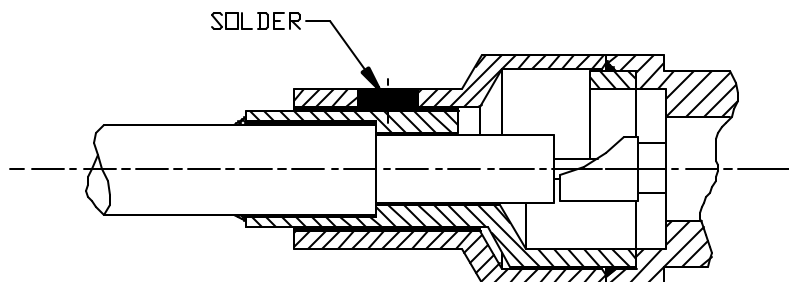

STEP 3

SEAT FERRULE ON BODY AND SOLDER FERRULE TO
BODY THROUGH SOLDER HOLE. CLEAN.

| | |
|-------------------------------|----------------|
| CABLE ASSEMBLY PROCEDURE | |
| P/N | 15-0020-0860 |
| PAGE 2 OF 2 | DATE: 06/15/04 |
| DRAWN: EK | APPROVED: JEM |
| FOR USE WITH T-FLEX 405 CABLE | |

PALEO
CONNECTOR

22 GREAT HILL ROAD, NAUGATUCK, CT. 06770
PHONE: (203) 729-9090 FAX: (203) 723-1794

| REV | DESCRIPTION | DATE | APPR |
|-----|--------------|----------|------|
| D | PER ECN 7475 | 06/14/04 | JEM |
| | | | |
| | | | |
| | | | |

FOR USE WITH T-FLEX 405 CABLE

STEP 1

TIN DIP CABLE TO DIMENSIONS SHOWN.

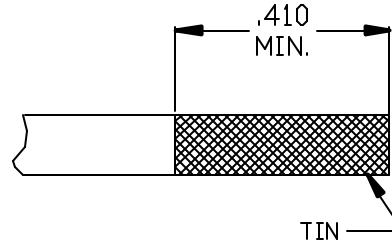

STEP 2

TRIM CABLE TO DIMENSIONS SHOWN
TIN CENTER CONDUCTOR.

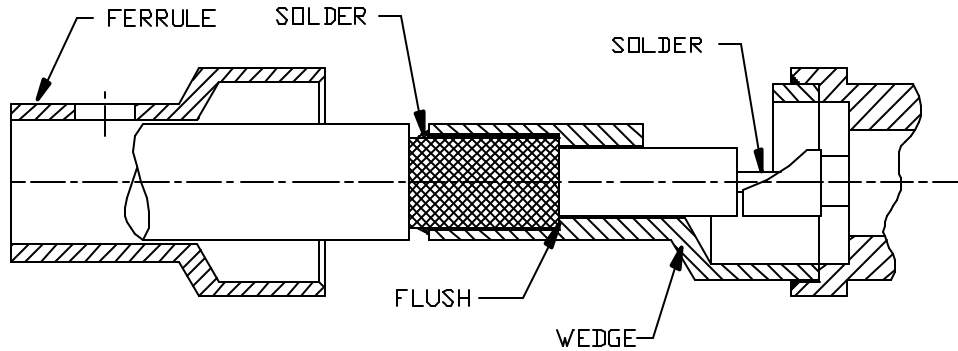
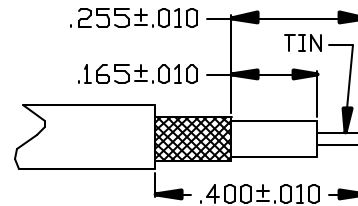

STEP 3

SLIDE FERRULE OVER CABLE.
INSERT CABLE INTO WEDGE UNTIL OUTER CONDUCTOR IS FLUSH WITH INSIDE DIAMETER OF WEDGE. CENTER CONDUCTOR MUST PROTRUDE INTO CONTACT. SOLDER CENTER CONDUCTOR INTO CONTACT AND OUTER CONDUCTOR INTO WEDGE. CLEAN.

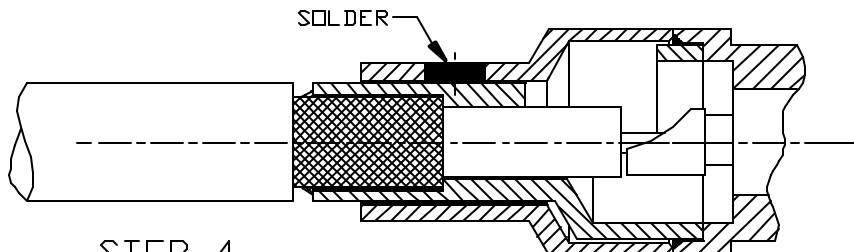

STEP 4

SEAT FERRULE ON BODY AND SOLDER FERRULE TO BODY THROUGH SOLDER HOLE. CLEAN.