

4

3

2

1

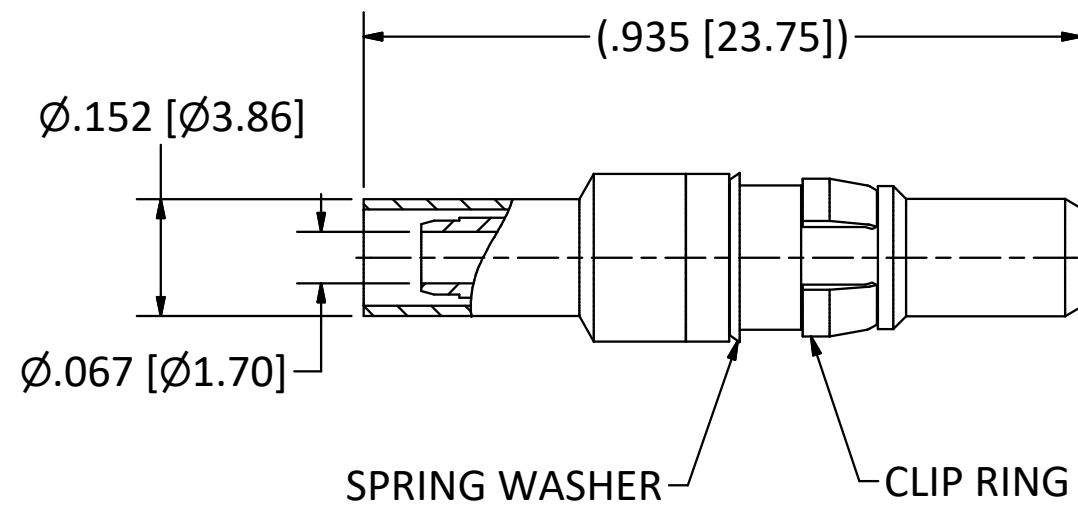
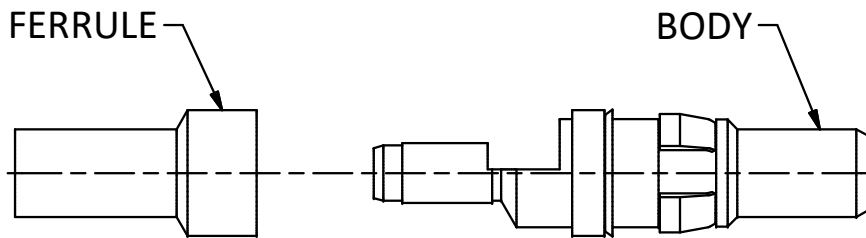

NOTES:

- 1. SPECIFICATIONS PER IDS-15J.
 - 2. FERRULE SHIPPED LOOSE.
 - 3. ACCOMMODATES RG-174, RG-179, RG-187, RG-188, OR RG-316 CABLE.
 - 4. MAGNETISM: <1.00000 mu.
 - 5. CRIMP USING .128 HEX DIE (M22520/5-03).
- HOUSING:** D-SUBMINIATURE, SIZE 8 CAVITY.

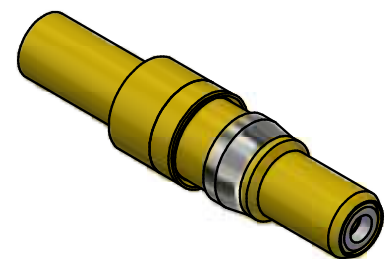

SCALE 2.5 : 1

This drawing embodies a proprietary design of The Phoenix Company of Chicago, Inc., Naugatuck, CT 06770. All design, manufacturing, reproduction, use, sale, and other rights regarding the same are expressly reserved. The information in this drawing may be covered completely or in part by patents and/or patents pending.				WARNING - THIS DOCUMENT CONTAINS TECHNICAL DATA WHOSE EXPORT IS RESTRICTED BY THE ARMS EXPORT CONTROL ACT (TITLE 22, U.S.C., SEC 2751, ET. SEQ.) OR THE EXPORT ADMINISTRATION ACT OF 1979, AS AMENDED, TITLE 50, U.S.C., APP 2401 ET SEQ. VIOLATIONS OF THESE EXPORT LAWS ARE SUBJECT TO SEVERE CRIMINAL PENALTIES. DISSEMINATE IN ACCORDANCE WITH PROVISIONS OF DOD DIRECTIVE 5230.25.		Filename: ver2\Autodesk Inventor Data Base\Assemblies\15 Series\15-0080-0670J-CU.idw		The PHOENIX Company of Chicago, Inc. 22 GREAT HILL RD., NAUGATUCK, CT 06770 WWW.PHOENIXOFCHICAGO.COM PHONE: (800) 323-9562 FAX:(630) 206-1801																			
						UNLESS OTHERWISE SPECIFIED, PHOENIX WORKMANSHIP STANDARDS APPLY DIMENSIONS IN INCHES OR (METRIC) DO NOT SCALE PRINTS TOLERANCES ARE: FRACTIONS: ± 1/64 DECIMALS: .XX ± .01 .XXX ± .003 ANGLES: ± 1/2°				<table border="1"> <thead> <tr> <th>APPROVALS</th> <th>DATE</th> </tr> </thead> <tbody> <tr> <td>DRAWN EK</td> <td>10/19/2006</td> </tr> <tr> <td>CHECKED JEM</td> <td>10/19/2006</td> </tr> <tr> <td>QA</td> <td></td> </tr> <tr> <td>MFG</td> <td></td> </tr> <tr> <td>ENGINEER EK</td> <td>10/19/2006</td> </tr> <tr> <td>APPROVED JEM</td> <td>10/19/2006</td> </tr> </tbody> </table>		APPROVALS	DATE	DRAWN EK	10/19/2006	CHECKED JEM	10/19/2006	QA		MFG		ENGINEER EK	10/19/2006	APPROVED JEM	10/19/2006	TITLE PDM PLUG, CRIMP TERMINATION	
APPROVALS	DATE																										
DRAWN EK	10/19/2006																										
CHECKED JEM	10/19/2006																										
QA																											
MFG																											
ENGINEER EK	10/19/2006																										
APPROVED JEM	10/19/2006																										
<table border="1"> <thead> <tr> <th>REV.</th> <th>DESCRIPTION</th> <th>DATE</th> <th>BY</th> </tr> </thead> <tbody> <tr> <td>E</td> <td>ECN 13676</td> <td>2/6/20</td> <td>JEM</td> </tr> <tr> <td>D</td> <td>ECN 13192</td> <td>11/20/18</td> <td>JEM</td> </tr> <tr> <td>C</td> <td>ECN 8700</td> <td>10/9/06</td> <td>JEM</td> </tr> </tbody> </table>		REV.	DESCRIPTION	DATE	BY	E	ECN 13676	2/6/20	JEM	D	ECN 13192	11/20/18	JEM	C	ECN 8700	10/9/06	JEM	SIZE B		FSCM 58167		DWG NO 15-0080-0670J		REV E		PLATING OPT.	
REV.	DESCRIPTION	DATE	BY																								
E	ECN 13676	2/6/20	JEM																								
D	ECN 13192	11/20/18	JEM																								
C	ECN 8700	10/9/06	JEM																								
				SCALE 2.5 : 1		F.S.R. #		SHEET 1 OF 1																			

4

3

2

1