

4

3

2

1

FERRULE

BODY

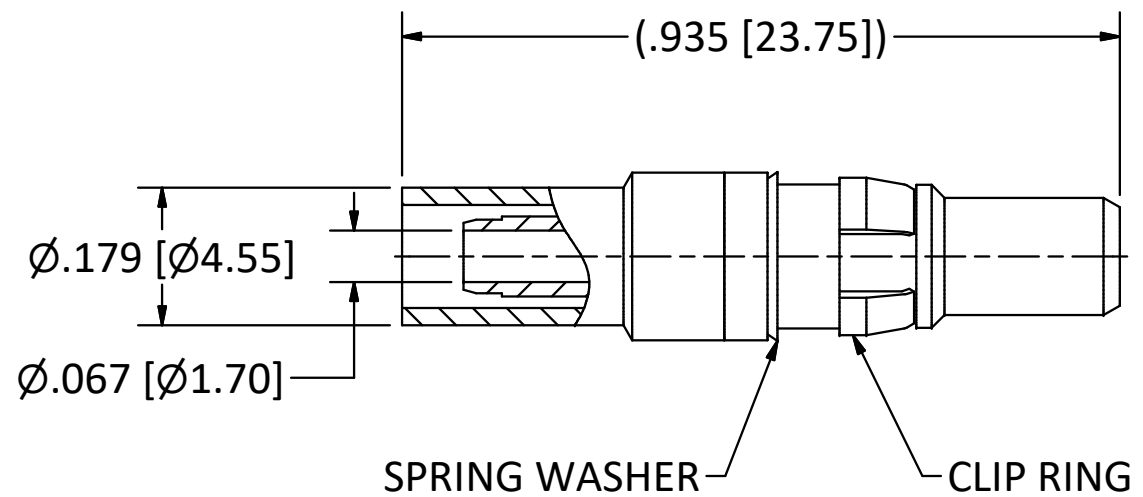

NOTES:

- 1. SPECIFICATIONS PER IDS-15J.
 - 2. FERRULE SHIPPED LOOSE.
 - 3. ACCOMMODATES RG-316 DOUBLE SHIELD (M17/152) CABLE.
 - 4. CRIMP USING .151 HEX DIE Y-138 (M22520/5-37).
 - 5. MAGNETISM: <1.00000 mu.
- HOUSING:** D-SUBMINIATURE, SIZE 8 CAVITY.

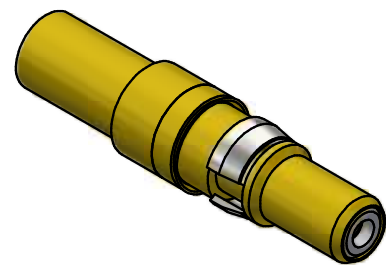

SCALE 2.5 : 1

F	ECN 11797	11/11/13	JEM
E	ECN 11243	1/30/12	JEM
REV.	DESCRIPTION	DATE	BY

This drawing embodies a proprietary design of The Phoenix Company of Chicago, Inc., Naugatuck, CT 06770. All design, manufacturing, reproduction, use, sale, and other rights regarding the same are expressly reserved. The information in this drawing may be covered completely or in part by patents and/or patents pending.

WARNING - THIS DOCUMENT CONTAINS TECHNICAL DATA WHOSE EXPORT IS RESTRICTED BY THE ARMS EXPORT CONTROL ACT (TITLE 22, U.S.C., SEC 2751, ET. SEQ.) OR THE EXPORT ADMINISTRATION ACT OF 1979, AS AMENDED, TITLE 50, U.S.C., APP 2401 ET SEQ. VIOLATIONS OF THESE EXPORT LAWS ARE SUBJECT TO SEVERE CRIMINAL PENALTIES. DISSEMINATE IN ACCORDANCE WITH PROVISIONS OF DOD DIRECTIVE 5230.25.

Filename: ver2\Autodesk Inventor Data Base\Assemblies\15 Series\15-0080-2670J-CU.idw

UNLESS OTHERWISE SPECIFIED, PHOENIX WORKMANSHIP STANDARDS APPLY DIMENSIONS IN INCHES OR (METRIC)

DO NOT SCALE PRINTS
TOLERANCES ARE:
FRACTIONS: ± 1/64
DECIMALS: .XX ± .01
.XXX ± .003
ANGLES: ± 1/2°



APPROVALS	DATE
DRAWN JSV	1/30/2012
CHECKED HN	1/30/2012
QA	
MFG	
ENGINEER JSV	1/30/2012
APPROVED HN	1/30/2012

The PHOENIX Company of Chicago, Inc.

22 GREAT HILL RD., NAUGATUCK, CT 06770
WWW.PHOENIXOFCHICAGO.COM
PHONE: (800) 323-9562 FAX:(630) 206-1801

TITLE				
PDM PLUG, CRIMP TERMINATION				
SIZE B	FSCM 58167	DWG NO 15-0080-2670J	REV	PLATING OPT.
SCALE 4 : 1	F.S.R. #	SHEET 1	OF 1	

4

3

2

1