

4

3

2

1

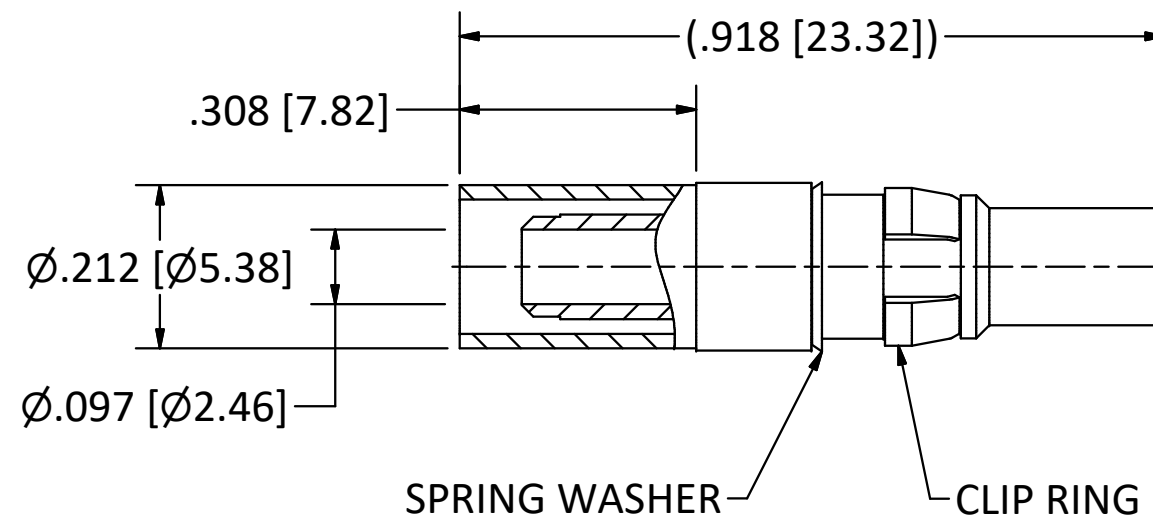
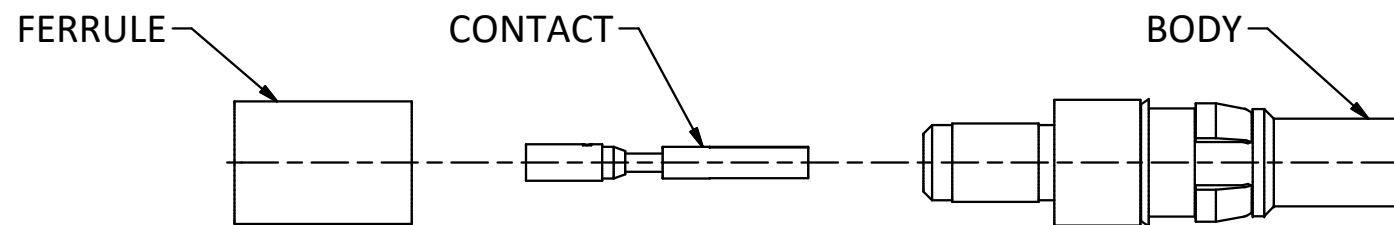

NOTES:

- 1. SPECIFICATIONS PER IDS-15.
 - 2. CONTACT AND FERRULE SHIPPED LOOSE.
 - 3. ACCOMMODATES EMTEQ, TFLX130-100, OR PIC S86208 CABLE.
 - 4. CRIMP WITH .178 HEX DIE (M22520/5-05).
- HOUSING:** D-SUBMINIATURE, SIZE 8 CAVITY.

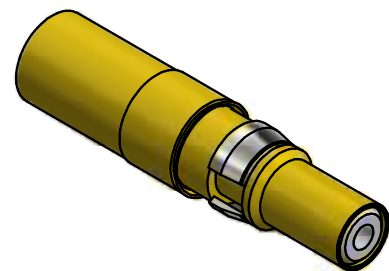

SCALE 2.5: 1

<p>This drawing embodies a proprietary design of The Phoenix Company of Chicago, Inc., Naugatuck, CT 06770. All design, manufacturing, reproduction, use, sale, and other rights regarding the same are expressly reserved. The information in this drawing may be covered completely or in part by patents and/or patents pending.</p>				<p>WARNING - THIS DOCUMENT CONTAINS TECHNICAL DATA WHOSE EXPORT IS RESTRICTED BY THE ARMS EXPORT CONTROL ACT (TITLE 22, U.S.C., SEC 2751, ET. SEQ.) OR THE EXPORT ADMINISTRATION ACT OF 1979, AS AMENDED, TITLE 50, U.S.C., APP 2401 ET SEQ. VIOLATIONS OF THESE EXPORT LAWS ARE SUBJECT TO SEVERE CRIMINAL PENALTIES. DISSEMINATE IN ACCORDANCE WITH PROVISIONS OF DOD DIRECTIVE 5230.25.</p>		<p>Filename: \\Autodesk Inventor Data Base\Assemblies\78 Series\78-1080-0670-CU-Layout for C Sized Drawing.idw</p>		<p>The PHOENIX Company of Chicago, Inc.</p> <p>22 GREAT HILL RD., NAUGATUCK, CT 06770 WWW.PHOENIXOFCHICAGO.COM</p> <p>PHONE: (800) 323-9562 FAX:(630) 206-1801</p>													
						<p>UNLESS OTHERWISE SPECIFIED, PHOENIX WORKMANSHIP STANDARDS APPLY DIMENSIONS IN INCHES OR (METRIC)</p> <p>DO NOT SCALE PRINTS</p> <p>TOLERANCES ARE: FRACTIONS: ± 1/64 DECIMALS: .XX ± .01 .XXX ± .003 ANGLES: ± 1/2°</p>		<table border="1"> <thead> <tr> <th>APPROVALS</th> <th>DATE</th> </tr> </thead> <tbody> <tr> <td>DRAWN MY</td> <td>12/23/1999</td> </tr> <tr> <td>CHECKED HN</td> <td>12/23/1999</td> </tr> <tr> <td>QA</td> <td></td> </tr> <tr> <td>MFG</td> <td></td> </tr> <tr> <td>ENGINEER MY</td> <td>12/23/1999</td> </tr> <tr> <td>APPROVED HN</td> <td>12/23/1999</td> </tr> </tbody> </table>		APPROVALS	DATE	DRAWN MY	12/23/1999	CHECKED HN	12/23/1999	QA		MFG		ENGINEER MY	12/23/1999
APPROVALS	DATE																				
DRAWN MY	12/23/1999																				
CHECKED HN	12/23/1999																				
QA																					
MFG																					
ENGINEER MY	12/23/1999																				
APPROVED HN	12/23/1999																				
<table border="1"> <thead> <tr> <th>A</th> <th>REL. ECN</th> <th>DATE</th> <th>HN</th> </tr> <tr> <th>REV</th> <th>DESCRIPTION</th> <th>DATE</th> <th>BY</th> </tr> </thead> <tbody> <tr> <td></td> <td>REL. ECN 5320</td> <td>12/23/99</td> <td>HN</td> </tr> </tbody> </table>		A	REL. ECN	DATE	HN	REV	DESCRIPTION	DATE	BY		REL. ECN 5320	12/23/99	HN	<p>SIZE B</p> <p>FSCM 58167</p>		<p>DWG NO 15-0090-2202</p>		<p>REV A</p> <p>PLATING OPT. A, B, C, D</p>			
A	REL. ECN	DATE	HN																		
REV	DESCRIPTION	DATE	BY																		
	REL. ECN 5320	12/23/99	HN																		
		<p>SCALE 4 : 1</p>		<p>F.S.R. #</p>		<p>SHEET 1 OF 1</p>															

4

3

2

1