

4

3

2

1

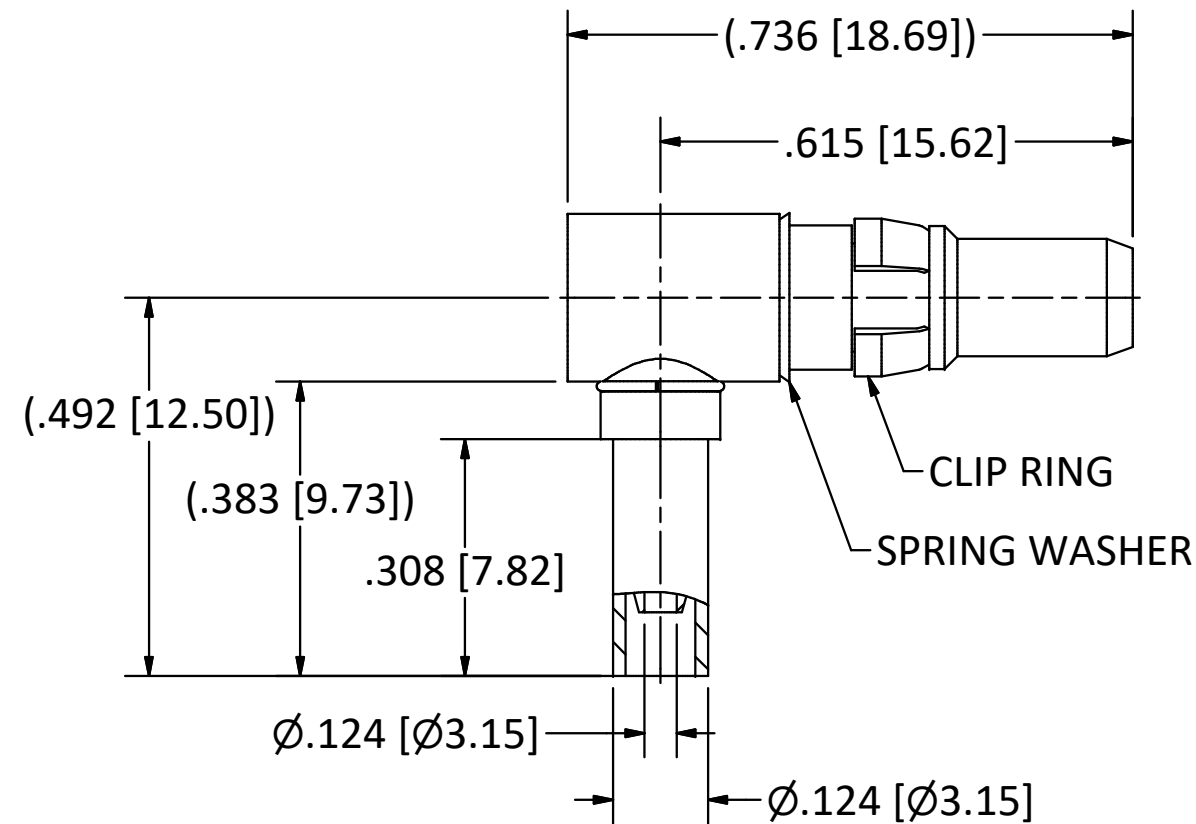
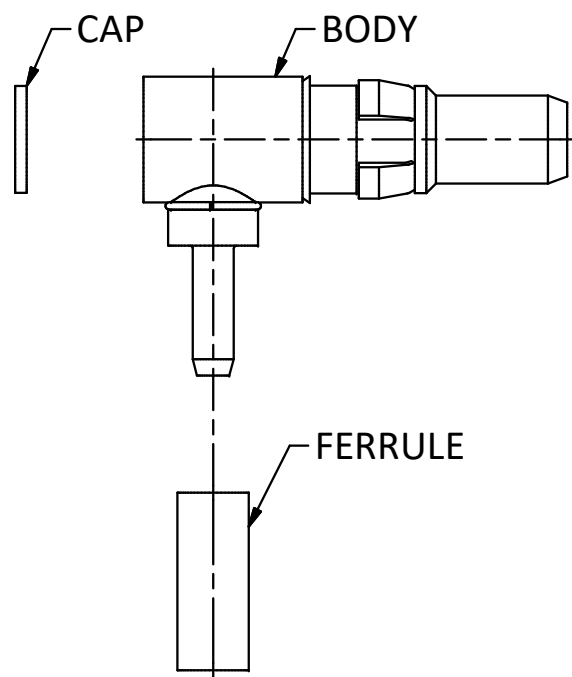

NOTES:

- 1. SPECIFICATIONS PER IDS-15J.
  - 2. CAP AND FERRULE SHIPPED LOOSE.
  - 3. ACCOMMODATES RG-178 OR RG-196 CABLE.
  - 4. CRIMP USING .123 HEX (M22520/5-03).
  - 5. MAGNETISM: <1.00000 mu.
- HOUSING:** D-SUBMINIATURE, SIZE 8 CAVITY.

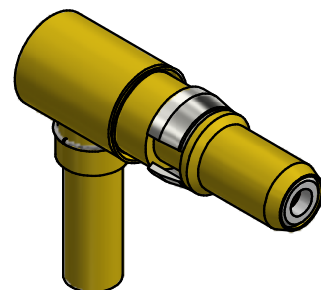

SCALE 2.5 : 1

B	PER ECN 8530	5/19/06	JEM
REV.	DESCRIPTION	DATE	BY

This drawing embodies a proprietary design of The Phoenix Company of Chicago, Inc., Naugatuck, CT 06770. All design, manufacturing, reproduction, use, sale, and other rights regarding the same are expressly reserved. The information in this drawing may be covered completely or in part by patents and/or patents pending.

WARNING - THIS DOCUMENT CONTAINS TECHNICAL DATA WHOSE EXPORT IS RESTRICTED BY THE ARMS EXPORT CONTROL ACT (TITLE 22, U.S.C., SEC 2751, ET. SEQ.) OR THE EXPORT ADMINISTRATION ACT OF 1979, AS AMENDED, TITLE 50, U.S.C., APP 2401 ET SEQ. VIOLATIONS OF THESE EXPORT LAWS ARE SUBJECT TO SEVERE CRIMINAL PENALTIES. DISSEMINATE IN ACCORDANCE WITH PROVISIONS OF DOD DIRECTIVE 5230.25.

Filename: ver2\Autodesk Inventor Data Base\Assemblies\15 Series\15-0580-0400J-CU.idw

UNLESS OTHERWISE SPECIFIED, PHOENIX WORKMANSHIP STANDARDS APPLY DIMENSIONS IN INCHES OR (METRIC)

DO NOT SCALE PRINTS  
TOLERANCES ARE:  
FRACTIONS: ± 1/64  
DECIMALS: .XX ± .01  
.XXX ± .003  
ANGLES: ± 1/2°



APPROVALS	DATE
DRAWN EK	5/23/2006
CHECKED JEM	5/23/2006
QA	
MFG	
ENGINEER EK	5/23/2006
APPROVED JEM	5/23/2006

**The PHOENIX Company of Chicago, Inc.**

22 GREAT HILL RD., NAUGATUCK, CT 06770  
WWW.PHOENIXOFCHICAGO.COM  
PHONE: (800) 323-9562 FAX:(630) 206-1801

TITLE <b>PDM RIGHT ANGLE PLUG, CRIMP TERMINATION</b>					
SIZE B	FSCM 58167	DWG NO <b>15-0580-0400J</b>	REV B	PLATING OPT.	
SCALE	4 : 1	F.S.R. #	SHEET	1	OF 1

4

3

2

1