

- NOTES:
1. SPECIFICATIONS PER IDS-15J.
  2. FERRULE AND CAP SHIPPED LOOSE.
  3. ACCOMMODATES RG-58, RG-141, OR RG-303 CABLE.
  4. CRIMP USING .213 HEX (M22520/5-05).
  5. MAGNETISM: <1.00000 mu.
- HOUSING:** D-SUBMINIATURE, SIZE 8 CAVITY.

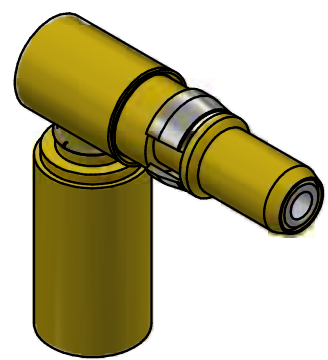

SCALE 2.5 : 1

REV.	DESCRIPTION	DATE	BY
C	PER ECN 6585	4/17/02	HN
B	PER ECN 5155	7/20/99	HN

This drawing embodies a proprietary design of The Phoenix Company of Chicago, Inc., Naugatuck, CT 06770. All design, manufacturing, reproduction, use, sale, and other rights regarding the same are expressly reserved. The information in this drawing may be covered completely or in part by patents and/or patents pending.

WARNING - THIS DOCUMENT CONTAINS TECHNICAL DATA WHOSE EXPORT IS RESTRICTED BY THE ARMS EXPORT CONTROL ACT (TITLE 22, U.S.C., SEC 2751, ET. SEQ.) OR THE EXPORT ADMINISTRATION ACT OF 1979, AS AMENDED, TITLE 50, U.S.C., APP 2401 ET SEQ. VIOLATIONS OF THESE EXPORT LAWS ARE SUBJECT TO SEVERE CRIMINAL PENALTIES. DISSEMINATE IN ACCORDANCE WITH PROVISIONS OF DOD DIRECTIVE 5230.25.

Filename: ver2\Autodesk Inventor Data Base\Assemblies\15 Series\15-0580-1201J-CU.idw		
UNLESS OTHERWISE SPECIFIED, PHOENIX WORKMANSHIP STANDARDS APPLY DIMENSIONS IN INCHES OR (METRIC)	APPROVALS	DATE
	DRAWN KJT	2/18/1978
DO NOT SCALE PRINTS	CHECKED DLD	2/18/1978
	QA	
TOLERANCES ARE: FRACTIONS: ± 1/64 DECIMALS: .XX ± .01 .XXX ± .003 ANGLES: ± 1/2°	MFG	
	ENGINEER HN	2/18/1978
	APPROVED DLD	2/18/1978

<b>The PHOENIX Company of Chicago, Inc.</b>					
22 GREAT HILL RD., NAUGATUCK, CT 06770 WWW.PHOENIXOFCHICAGO.COM PHONE: (800) 323-9562 FAX:(630) 206-1801					
TITLE <b>PDM RIGHT ANGLE PLUG, CRIMP TERMINATION</b>					
SIZE B	FSCM 58167	DWG NO <b>15-0580-1201J</b>	REV C	PLATING OPT.	
SCALE 4 : 1	F.S.R. #	SHEET 1 OF 1			