

CABLE ASSEMBLY PROCEDURE		<b>PALEO</b> <b>CONNECTOR</b> 22 GREAT HILL ROAD, NAUGATUCK, CT. 06770 PHONE: (203) 729-9090 FAX: (203) 723-1794	REV	DESCRIPTION	DATE	APPR
P/N	15-1020-0001		C	PER ECN 6423	2/19/02	HN
PAGE 1 OF 1	DATE: 2/19/02		D	PER ECN 10519	08/16/10	JEM
DRAWN: JSV	APPROVED: HN					
FOR USE #8 AWG WIRE						

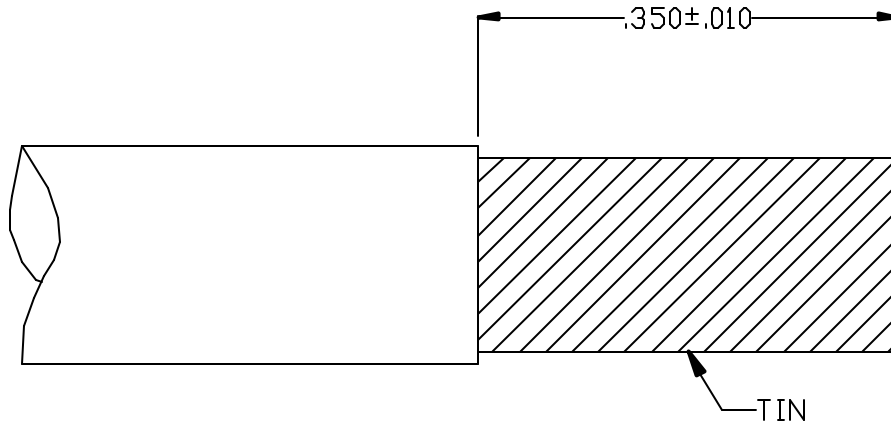

STEP 1

TRIM WIRE TO DIMENSIONS SHOWN.  
TIN CENTER CONDUCTOR.

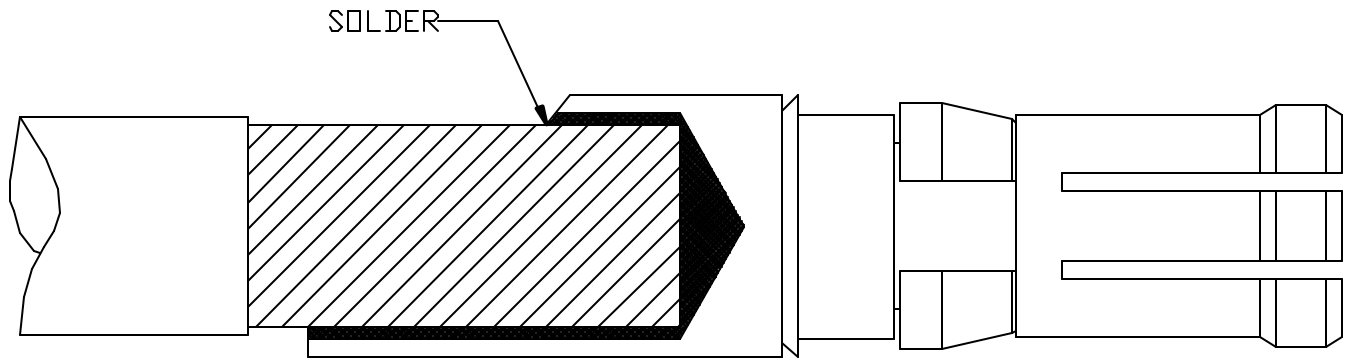

STEP 2

SOLDER WIRE TO THE BODY AS SHOWN.  
CLEAN AND INSPECT SOLDER JOINT.