

CABLE ASSEMBLY PROCEDURE		<b>PALEO</b> <b>CONNECTOR</b> 22 GREAT HILL ROAD, NAUGATUCK, CT. 06770 PHONE: (203) 729-9090 FAX: (203) 723-1794	REV	DESCRIPTION	DATE	APPR
P/N	15-1020-0002		E	PER ECN 6390	01/08/02	HN
PAGE 1 OF 1	DATE: 01/08/02		F	PER ECN 7740	12/10/04	JM
DRAWN: RVR	APPROVED: HN		G	PER ECN 10517	08/16/10	JEM
FOR USE #12 AWG WIRE						

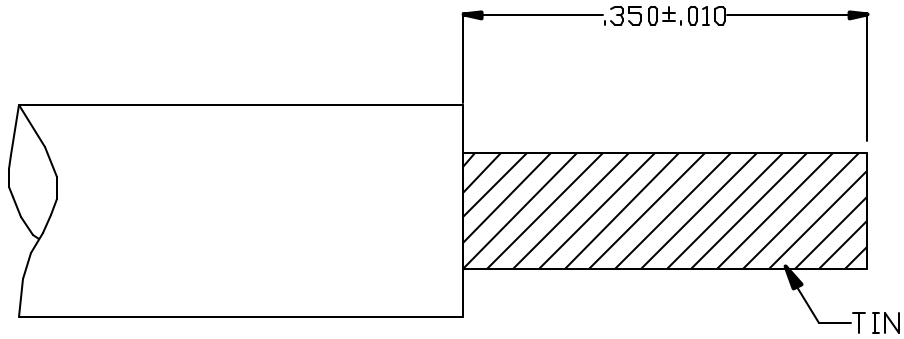

STEP 1

TRIM WIRE TO DIMENSIONS SHOWN.  
 TIN CENTER CONDUCTOR.

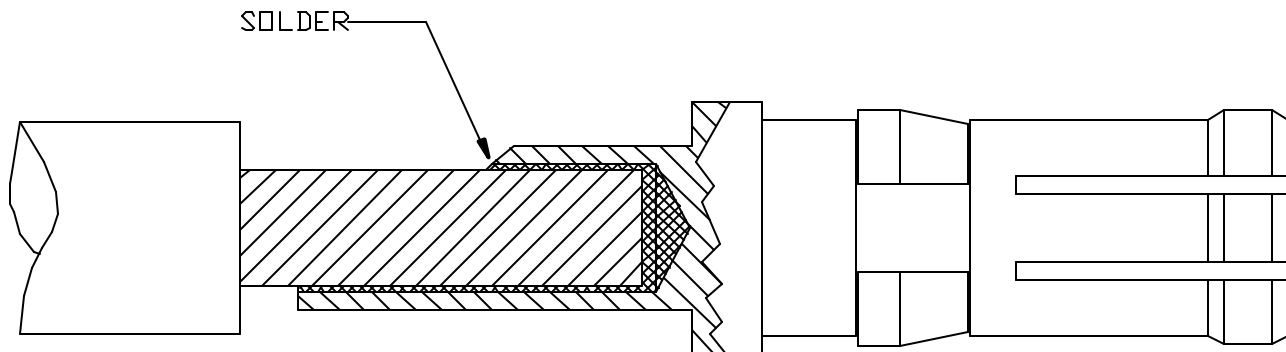

STEP 2

SOLDER WIRE TO THE BODY AS SHOWN.  
 CLEAN AND INSPECT SOLDER JOINT.