

4

3

2

1

B

B

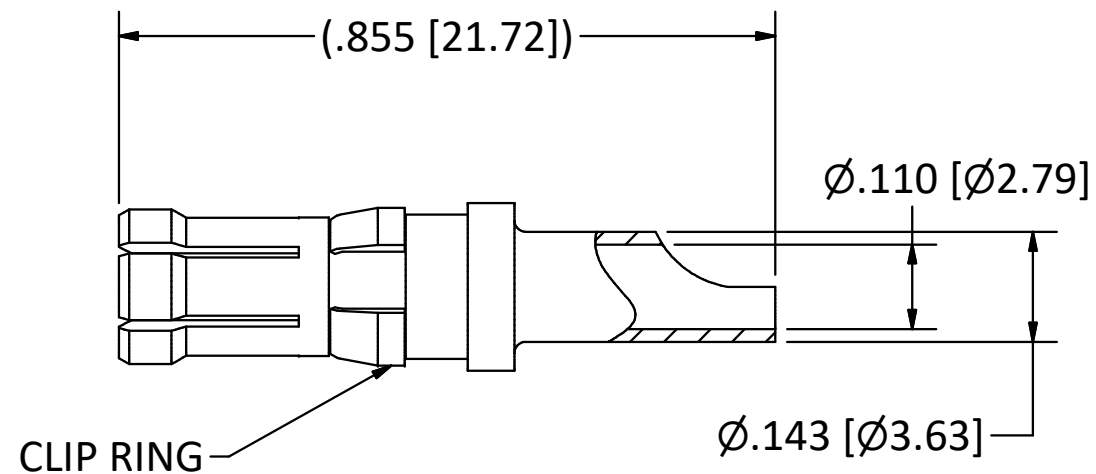

- NOTES:
1. SPECIFICATIONS PER IDS-15J.
 2. ACCOMMODATES 12 OR 14 AWG STRANDED WIRE.
 3. MAGNETISM: <1.00000 mu.
- HOUSING:** D-SUBMINIATURE, SIZE 8 CAVITY.

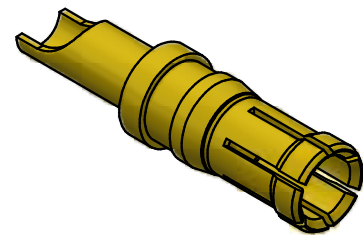

SCALE 2.5 : 1

4

3

2

1

A

A

<p>This drawing embodies a proprietary design of The Phoenix Company of Chicago, Inc., Naugatuck, CT 06770. All design, manufacturing, reproduction, use, sale, and other rights regarding the same are expressly reserved. The information in this drawing may be covered completely or in part by patents and/or patents pending.</p>				<p>WARNING - THIS DOCUMENT CONTAINS TECHNICAL DATA WHOSE EXPORT IS RESTRICTED BY THE ARMS EXPORT CONTROL ACT (TITLE 22, U.S.C., SEC 2751, ET. SEQ.) OR THE EXPORT ADMINISTRATION ACT OF 1979, AS AMENDED, TITLE 50, U.S.C., APP 2401 ET SEQ. VIOLATIONS OF THESE EXPORT LAWS ARE SUBJECT TO SEVERE CRIMINAL PENALTIES. DISSEMINATE IN ACCORDANCE WITH PROVISIONS OF DOD DIRECTIVE 5230.25.</p>		<p>Filename: ver2\Autodesk Inventor Data Base\Assemblies\15 Series\15-1020-0002J-CU.idw</p>		<p>The PHOENIX Company of Chicago, Inc.</p> <p>22 GREAT HILL RD., NAUGATUCK, CT 06770 WWW.PHOENIXOFCHICAGO.COM</p> <p>PHONE: (800) 323-9562 FAX:(630) 206-1801</p>													
						<p>UNLESS OTHERWISE SPECIFIED, PHOENIX WORKMANSHIP STANDARDS APPLY DIMENSIONS IN INCHES OR (METRIC)</p> <p>DO NOT SCALE PRINTS</p> <p>TOLERANCES ARE: FRACTIONS: ± 1/64 DECIMALS: .XX ± .01 .XXX ± .003 ANGLES: ± 1/2°</p>		<table border="1"> <thead> <tr> <th>APPROVALS</th> <th>DATE</th> </tr> </thead> <tbody> <tr> <td>DRAWN YT</td> <td>10/12/2004</td> </tr> <tr> <td>CHECKED JM</td> <td>10/12/2004</td> </tr> <tr> <td>QA</td> <td></td> </tr> <tr> <td>MFG</td> <td></td> </tr> <tr> <td>ENGINEER YT</td> <td>10/12/2004</td> </tr> <tr> <td>APPROVED JM</td> <td>10/12/2004</td> </tr> </tbody> </table>		APPROVALS	DATE	DRAWN YT	10/12/2004	CHECKED JM	10/12/2004	QA		MFG		ENGINEER YT	10/12/2004
APPROVALS	DATE																				
DRAWN YT	10/12/2004																				
CHECKED JM	10/12/2004																				
QA																					
MFG																					
ENGINEER YT	10/12/2004																				
APPROVED JM	10/12/2004																				
<table border="1"> <thead> <tr> <th>REV.</th> <th>DESCRIPTION</th> <th>DATE</th> <th>BY</th> </tr> </thead> <tbody> <tr> <td>G</td> <td>PER ECN 10517</td> <td>08/16/10</td> <td>JEM</td> </tr> <tr> <td>F</td> <td>PER ECN7740</td> <td>12/10/04</td> <td>JM</td> </tr> </tbody> </table>		REV.	DESCRIPTION	DATE	BY	G	PER ECN 10517	08/16/10	JEM	F	PER ECN7740	12/10/04	JM			<p>SIZE B FSCM 58167</p>		<p>DWG NO 15-1020-0002J</p>		<p>REV G PLATING OPT.</p>	
REV.	DESCRIPTION	DATE	BY																		
G	PER ECN 10517	08/16/10	JEM																		
F	PER ECN7740	12/10/04	JM																		
				<p>SCALE 4 : 1</p>		<p>F.S.R. #</p>		<p>SHEET 1 OF 1</p>													