

CABLE ASSEMBLY PROCEDURE		PALEO CONNECTOR 22 GREAT HILL ROAD, NAUGATUCK, CT. 06770 PHONE: (203) 729-9090 FAX: (203) 723-1794	REV	DESCRIPTION	DATE	APPR
P/N	15-1020-0003		F	PER ECN 7213	11/25/03	HN
PAGE 1 OF 1	DATE: 11/25/03		G	PER ECN 10520	08/16/10	JEM
DRAWN: RVR	APPROVED: HN					
FOR USE #12 AWG WIRE						

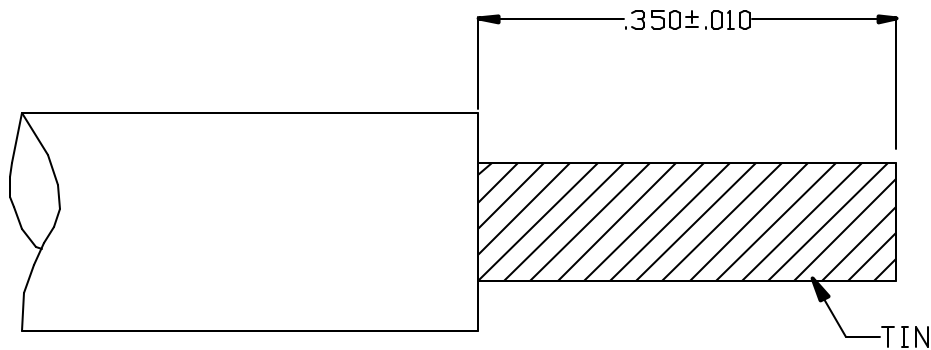

STEP 1

TRIM WIRE TO DIMENSIONS SHOWN.
TIN CENTER CONDUCTOR.

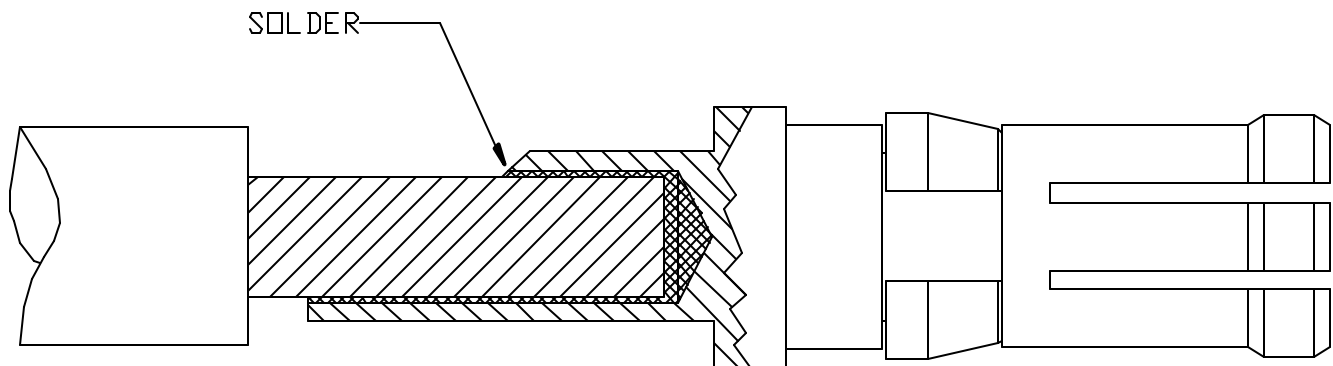

STEP 2

SOLDER WIRE TO THE BODY AS SHOWN.
CLEAN AND INSPECT SOLDER JOINT.