

4

3

2

1

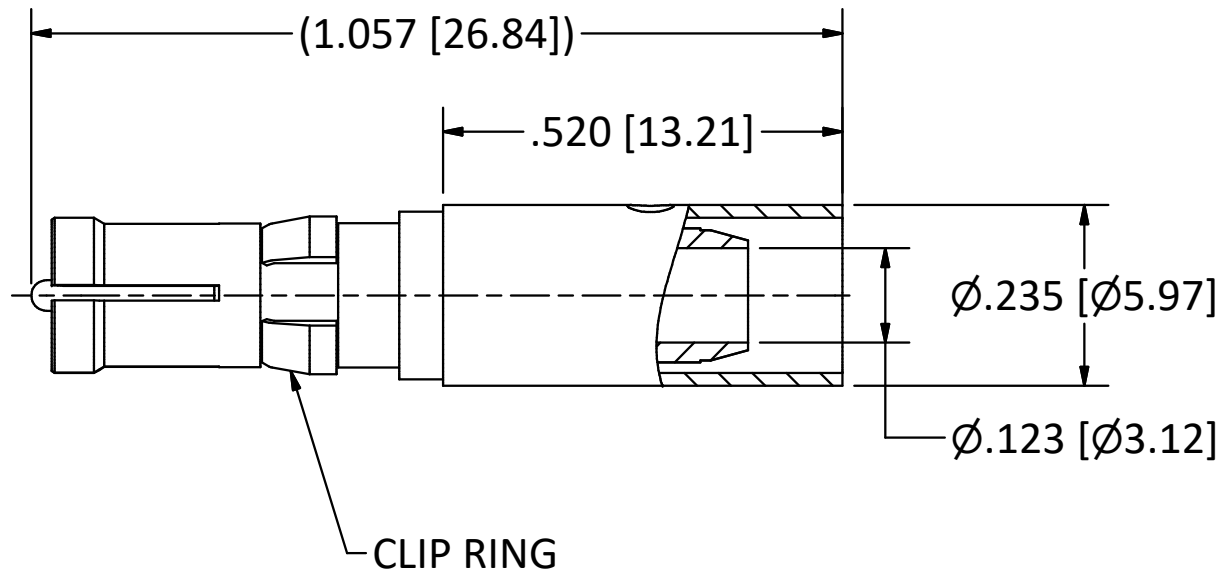
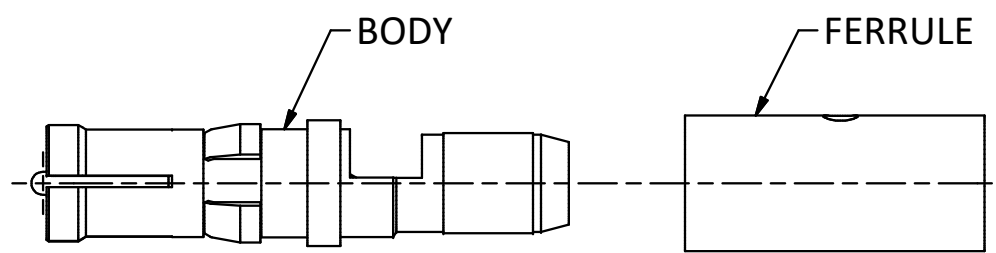

- NOTES:
1. SPECIFICATIONS PER IDS 15J.
 2. FERRULE SHIPPED LOOSE.
 3. ACCOMMODATES RG-58, RG-141, OR RG-303 CABLE.
 4. MAGNETISM: <math><1.00000\text{ mu}</math>.
- HOUSING:** D-SUBMINIATURE, SIZE 8 CAVITY.

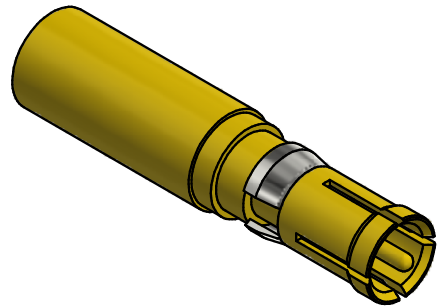

SCALE 2.5: 1

REV.	DESCRIPTION	DATE	BY
E	ECN 13342	6/19/2019	JEM
D	ECN 10577	9/1/10	JEM
C	ECN 6819	12/03/02	HN
B	ECN 5144	7/12/99	HN
A	ECN 1154	5/24/88	YT

This drawing embodies a proprietary design of The Phoenix Company of Chicago, Inc., Naugatuck, CT 06770. All design, manufacturing, reproduction, use, sale, and other rights regarding the same are expressly reserved. The information in this drawing may be covered completely or in part by patents and/or patents pending.

WARNING - THIS DOCUMENT CONTAINS TECHNICAL DATA WHOSE EXPORT IS RESTRICTED BY THE ARMS EXPORT CONTROL ACT (TITLE 22, U.S.C., SEC 2751, ET. SEQ.) OR THE EXPORT ADMINISTRATION ACT OF 1979, AS AMENDED, TITLE 50, U.S.C., APP 2401 ET SEQ. VIOLATIONS OF THESE EXPORT LAWS ARE SUBJECT TO SEVERE CRIMINAL PENALTIES. DISSEMINATE IN ACCORDANCE WITH PROVISIONS OF DOD DIRECTIVE 5230.25.

Filename: ver2\Autodesk Inventor Data Base\Assemblies\15 Series\15-1020-1201J-CU.idw		
UNLESS OTHERWISE SPECIFIED, PHOENIX WORKMANSHIP STANDARDS APPLY DIMENSIONS IN INCHES OR (METRIC) DO NOT SCALE PRINTS TOLERANCES ARE: FRACTIONS: $\pm 1/64$ DECIMALS: $.XX \pm .01$ $.XXX \pm .003$ ANGLES: $\pm 1/2^\circ$	APPROVALS	DATE
	DRAWN RVR	7/12/1999
	CHECKED HN	7/12/1999
	QA	
	MFG	
	ENGINEER HN	7/12/1999
APPROVED HN	7/12/1999	

The PHOENIX Company of Chicago, Inc.
 22 GREAT HILL RD., NAUGATUCK, CT 06770
 WWW.PHOENIXOFCHICAGO.COM
 PHONE: (800) 323-9562 FAX:(630) 206-1801

TITLE
PDM JACK, DIRECT SOLDER TERMINATION

SIZE B	FSCM 58167	DWG NO 15-1020-1201J	REV E	PLATING OPT.
SCALE 4 : 1	F.S.R. #	SHEET 1	OF 1	

4

3

2

1