

CABLE ASSEMBLY PROCEDURE		 22 GREAT HILL ROAD, NAUGATUCK, CT. 06770 PHONE: (203) 729-9090 FAX: (203) 723-1794	REV	DESCRIPTION	DATE	APPR
P/N	15-1080-0001		D	PER ECN 5810	10/31/01	HN
PAGE 1 OF 1	DATE: 10/31/01		E	PER ECN 10565	08/30/10	JEM
DRAWN: JSV	APPROVED: HN					
FOR USE #8/10 AWG WIRE						

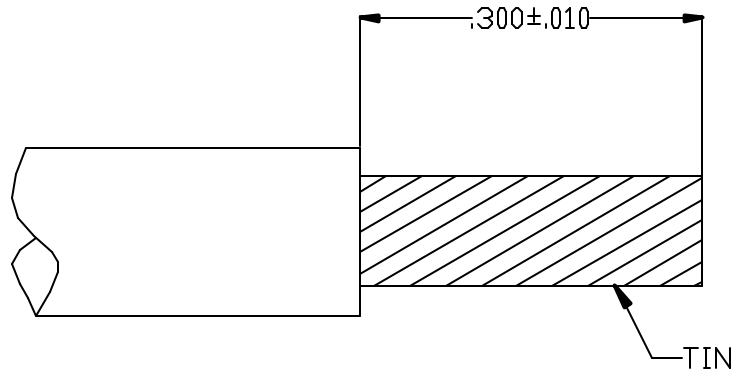

STEP 1

TRIM WIRE TO DIMENSIONS SHOWN.
TIN CENTER CONDUCTOR.

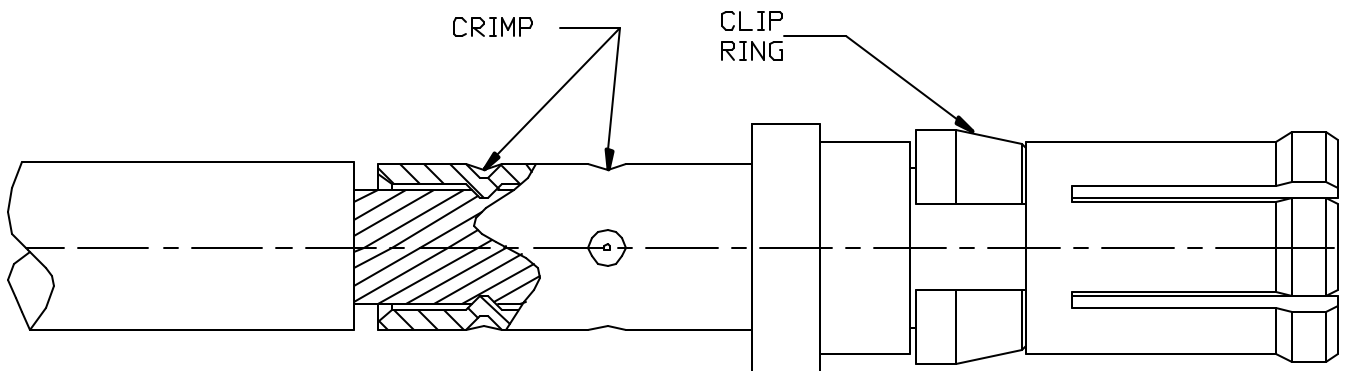

STEP 2

CRIMP WITH DANIELS CRIMP TOOL FT8,
PALCO'S POSITIONER T0623 USING SETTING 5 FOR #8 AWG WIRE
AND SETTING 4 FOR # 10 AWG WIRE.