

4

3

2

1

B

B

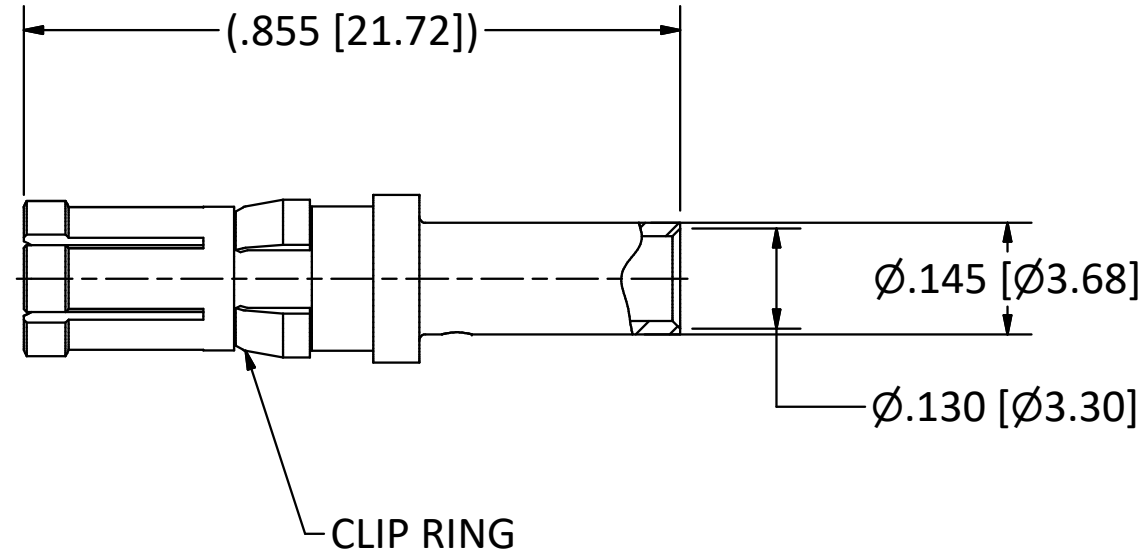

- NOTES:
1. SPECIFICATIONS PER IDS-15P.
 2. ACCOMMODATES 12 OR 14 AWG STRANDED WIRE.
 3. CRIMP USING .213 HEX DIE (M22520-0-05).
- HOUSING:** D-SUBMINIATURE, SIZE 8 CAVITY.

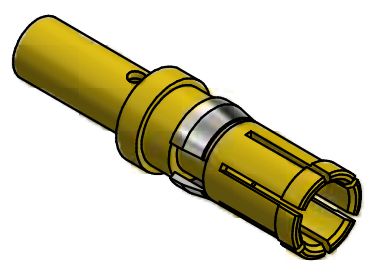

SCALE 2.5 : 1

4

3

2

1

A

A

<p>This drawing embodies a proprietary design of The Phoenix Company of Chicago, Inc., Naugatuck, CT 06770. All design, manufacturing, reproduction, use, sale, and other rights regarding the same are expressly reserved. The information in this drawing may be covered completely or in part by patents and/or patents pending.</p>				<p>WARNING - THIS DOCUMENT CONTAINS TECHNICAL DATA WHOSE EXPORT IS RESTRICTED BY THE ARMS EXPORT CONTROL ACT (TITLE 22, U.S.C., SEC 2751, ET. SEQ.) OR THE EXPORT ADMINISTRATION ACT OF 1979, AS AMENDED, TITLE 50, U.S.C., APP 2401 ET SEQ. VIOLATIONS OF THESE EXPORT LAWS ARE SUBJECT TO SEVERE CRIMINAL PENALTIES. DISSEMINATE IN ACCORDANCE WITH PROVISIONS OF DOD DIRECTIVE 5230.25.</p>		<p>Filename: \\Autodesk Inventor Data Base\Assemblies\78 Series\78-1080-0670-CU-Layout for C Sized Drawing.idw</p>		<p>The PHOENIX Company of Chicago, Inc. 22 GREAT HILL RD., NAUGATUCK, CT 06770 WWW.PHOENIXOFCHICAGO.COM PHONE: (800) 323-9562 FAX:(630) 206-1801</p>																	
						<p>UNLESS OTHERWISE SPECIFIED, PHOENIX WORKMANSHIP STANDARDS APPLY DIMENSIONS IN INCHES OR (METRIC)</p> <p>DO NOT SCALE PRINTS</p> <p>TOLERANCES ARE: FRACTIONS: ± 1/64 DECIMALS: .XX ± .01 .XXX ± .003 ANGLES: ± 1/2°</p>				<table border="1"> <thead> <tr> <th>APPROVALS</th> <th>DATE</th> </tr> </thead> <tbody> <tr> <td>DRAWN EW</td> <td>6/28/1995</td> </tr> <tr> <td>CHECKED HN</td> <td>6/28/1995</td> </tr> <tr> <td>QA</td> <td></td> </tr> <tr> <td>MFG</td> <td></td> </tr> <tr> <td>ENGINEER EW</td> <td>6/28/1995</td> </tr> <tr> <td>APPROVED HN</td> <td>6/28/1995</td> </tr> </tbody> </table>		APPROVALS	DATE	DRAWN EW	6/28/1995	CHECKED HN	6/28/1995	QA		MFG		ENGINEER EW	6/28/1995	APPROVED HN	6/28/1995
APPROVALS	DATE																								
DRAWN EW	6/28/1995																								
CHECKED HN	6/28/1995																								
QA																									
MFG																									
ENGINEER EW	6/28/1995																								
APPROVED HN	6/28/1995																								
<table border="1"> <thead> <tr> <th>REV</th> <th>DESCRIPTION</th> <th>DATE</th> <th>BY</th> </tr> </thead> <tbody> <tr> <td>E</td> <td>PER ECN 10529</td> <td>8/17/10</td> <td>JEM</td> </tr> <tr> <td>D</td> <td>PER ECN 6141</td> <td>5/31/01</td> <td>HN</td> </tr> </tbody> </table>		REV	DESCRIPTION	DATE	BY	E	PER ECN 10529	8/17/10	JEM	D	PER ECN 6141	5/31/01	HN	<table border="1"> <thead> <tr> <th>SIZE</th> <th>FSCM</th> <th>DWG NO</th> <th>REV</th> <th>PLATING OPT.</th> </tr> </thead> <tbody> <tr> <td>B</td> <td>58167</td> <td>15-1080-0002</td> <td>E</td> <td>A, B, C, D</td> </tr> </tbody> </table>		SIZE	FSCM	DWG NO	REV	PLATING OPT.	B	58167	15-1080-0002	E	A, B, C, D
REV	DESCRIPTION	DATE	BY																						
E	PER ECN 10529	8/17/10	JEM																						
D	PER ECN 6141	5/31/01	HN																						
SIZE	FSCM	DWG NO	REV	PLATING OPT.																					
B	58167	15-1080-0002	E	A, B, C, D																					
<table border="1"> <thead> <tr> <th>REV</th> <th>DESCRIPTION</th> <th>DATE</th> <th>BY</th> </tr> </thead> <tbody> <tr> <td>E</td> <td>PER ECN 10529</td> <td>8/17/10</td> <td>JEM</td> </tr> <tr> <td>D</td> <td>PER ECN 6141</td> <td>5/31/01</td> <td>HN</td> </tr> </tbody> </table>		REV	DESCRIPTION	DATE	BY	E	PER ECN 10529	8/17/10	JEM	D	PER ECN 6141	5/31/01	HN	<p>SCALE 2.5 : 1</p>		<p>F.S.R. #</p>		<p>SHEET 1 OF 1</p>							
REV	DESCRIPTION	DATE	BY																						
E	PER ECN 10529	8/17/10	JEM																						
D	PER ECN 6141	5/31/01	HN																						