

4

3

2

1

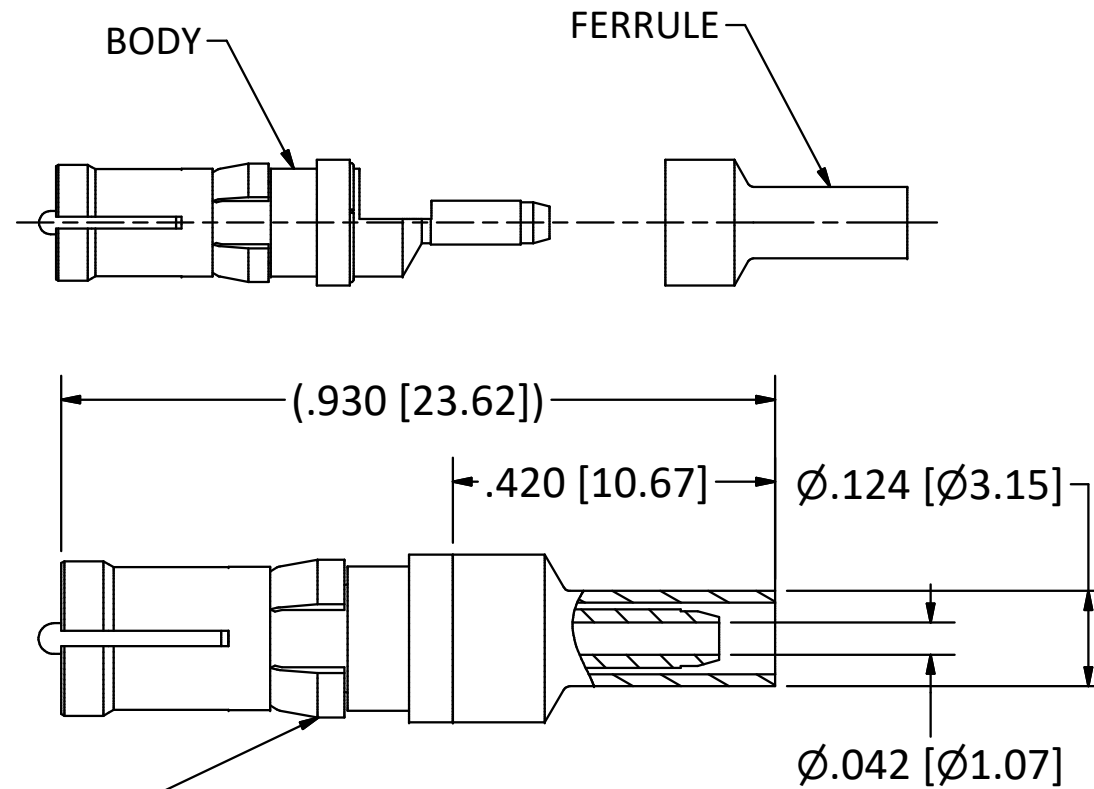

CLIP RING

NOTES:

- 1. SPECIFICATIONS PER IDS-15J.
- 2. FERRULE SHIPPED LOOSE.
- 3. ACCOMMODATES RG-178 OR RG-196 CABLE.
- 4. CRIMP USING .105 HEX DIE SET Y-196 (M22520/5-03).
- 5. MAGNETISM: <1.00000 mu.

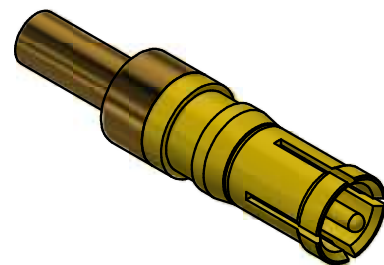

SCALE 2.5 : 1

<table border="1"> <tr> <td>E</td> <td>PER ECN 14099</td> <td>02/16/22</td> <td>A.P.</td> </tr> <tr> <td>REV.</td> <td>DESCRIPTION</td> <td>DATE</td> <td>BY</td> </tr> </table>				E	PER ECN 14099	02/16/22	A.P.	REV.	DESCRIPTION	DATE	BY	<p>This drawing embodies a proprietary design of The Phoenix Company of Chicago, Inc., Naugatuck, CT 06770. All design, manufacturing, reproduction, use, sale, and other rights regarding the same are expressly reserved. The information in this drawing may be covered completely or in part by patents and/or patents pending.</p>	<p>WARNING - THIS DOCUMENT CONTAINS TECHNICAL DATA WHOSE EXPORT IS RESTRICTED BY THE ARMS EXPORT CONTROL ACT (TITLE 22, U.S.C., SEC 2751, ET. SEQ.) OR THE EXPORT ADMINISTRATION ACT OF 1979, AS AMENDED, TITLE 50, U.S.C., APP 2401 ET SEQ. VIOLATIONS OF THESE EXPORT LAWS ARE SUBJECT TO SEVERE CRIMINAL PENALTIES. DISSEMINATE IN ACCORDANCE WITH PROVISIONS OF DOD DIRECTIVE 5230.25.</p>	Filename: ver2\Autodesk Inventor Data Base\Assemblies\15 Series\15-1080-0400J-CU.idw		<p>The PHOENIX Company of Chicago, Inc.</p> <p>22 GREAT HILL RD., NAUGATUCK, CT 06770 WWW.PHOENIXOFCHICAGO.COM</p> <p>PHONE: (800) 323-9562 FAX:(630) 206-1801</p>			
				E	PER ECN 14099	02/16/22	A.P.												
REV.	DESCRIPTION	DATE	BY																
UNLESS OTHERWISE SPECIFIED, PHOENIX WORKMANSHIP STANDARDS APPLY DIMENSIONS IN INCHES OR (METRIC)		APPROVALS DRAWN EY CHECKED HN QA MFG ENGINEER PP APPROVED HN	DATE 11/10/1992 11/10/1992	DO NOT SCALE PRINTS TOLERANCES ARE: FRACTIONS: ± 1/64 DECIMALS: .XX ± .01 .XXX ± .003 ANGLES: ± 1/2°		TITLE PDM RECEPTACLE, CRIMP TERMINATION													
				SIZE B FSCM 58167		DWG NO 15-1080-0400J		REV E	PLATING OPT.										
				SCALE 4 : 1		F.S.R. #		SHEET 1 OF 1											

4

3

2

1