

4

3

2

1

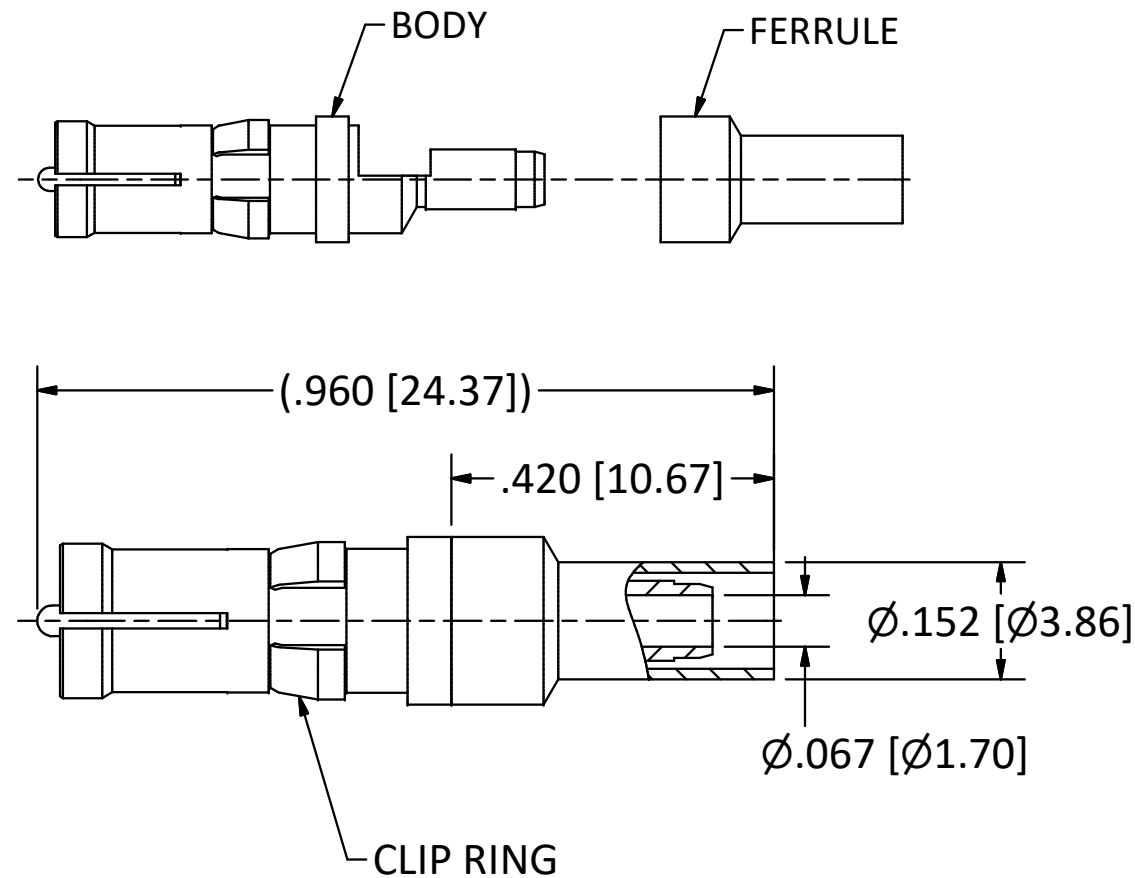

NOTES:

- 1. SPECIFICATIONS PER IDS-15J.
 - 2. FERRULE SHIPPED LOOSE.
 - 3. ACCOMMODATES RG-174, RG-179, RG-187, RG-188, OR RG-316 CABLE.
 - 4. MAGNETISM: <1.00000 mu.
 - 5. CRIMP USING .128 DIE SET Y-196 (M22520/5-03).
- HOUSING:** D-SUBMINIATURE, SIZE 8 CAVITY.

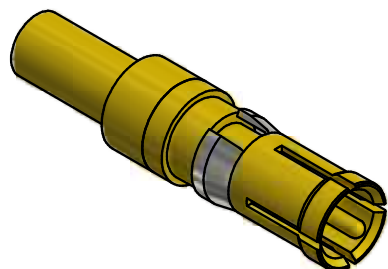

SCALE 2.5 : 1

REV.	DESCRIPTION	DATE	BY
F	ECN 13323	5/13/19	JEM
E	ECN 10522	8/16/10	JEM
D	ECN 6820	12/4/02	HN
C	ECN 6105	5/1/01	HN
B	ECN 5342	1/18/00	HN
A	ECN 1154	5/24/88	HN

This drawing embodies a proprietary design of The Phoenix Company of Chicago, Inc., Naugatuck, CT 06770. All design, manufacturing, reproduction, use, sale, and other rights regarding the same are expressly reserved. The information in this drawing may be covered completely or in part by patents and/or patents pending.

WARNING - THIS DOCUMENT CONTAINS TECHNICAL DATA WHOSE EXPORT IS RESTRICTED BY THE ARMS EXPORT CONTROL ACT (TITLE 22, U.S.C., SEC 2751, ET. SEQ.) OR THE EXPORT ADMINISTRATION ACT OF 1979, AS AMENDED, TITLE 50, U.S.C., APP 2401 ET SEQ. VIOLATIONS OF THESE EXPORT LAWS ARE SUBJECT TO SEVERE CRIMINAL PENALTIES. DISSEMINATE IN ACCORDANCE WITH PROVISIONS OF DOD DIRECTIVE 5230.25.

Filename: ver2\Autodesk Inventor Data Base\Assemblies\15 Series\15-1080-0670J-CU.idw

UNLESS OTHERWISE SPECIFIED, PHOENIX WORKMANSHIP STANDARDS APPLY DIMENSIONS IN INCHES OR (METRIC)

DO NOT SCALE PRINTS
TOLERANCES ARE:
FRACTIONS: ± 1/64
DECIMALS: .XX ± .01
.XXX ± .003
ANGLES: ± 1/2°

32√

APPROVALS	DATE
DRAWN RVR	10/11/2000
CHECKED HN	10/11/2000
QA	
MFG	
ENGINEER RVR	10/11/2000
APPROVED HN	10/11/2000

The PHOENIX Company of Chicago, Inc.

22 GREAT HILL RD., NAUGATUCK, CT 06770
WWW.PHOENIXOFCHICAGO.COM
PHONE: (800) 323-9562 FAX:(630) 206-1801

TITLE
PDM JACK, CRIMP TERMINATION

SIZE	FSCM	DWG NO	REV	PLATING OPT.
B	58167	15-1080-0670J	F	
SCALE	2.5 : 1	F.S.R. #	SHEET	1 OF 1

4

3

2

1