

4

3

2

1

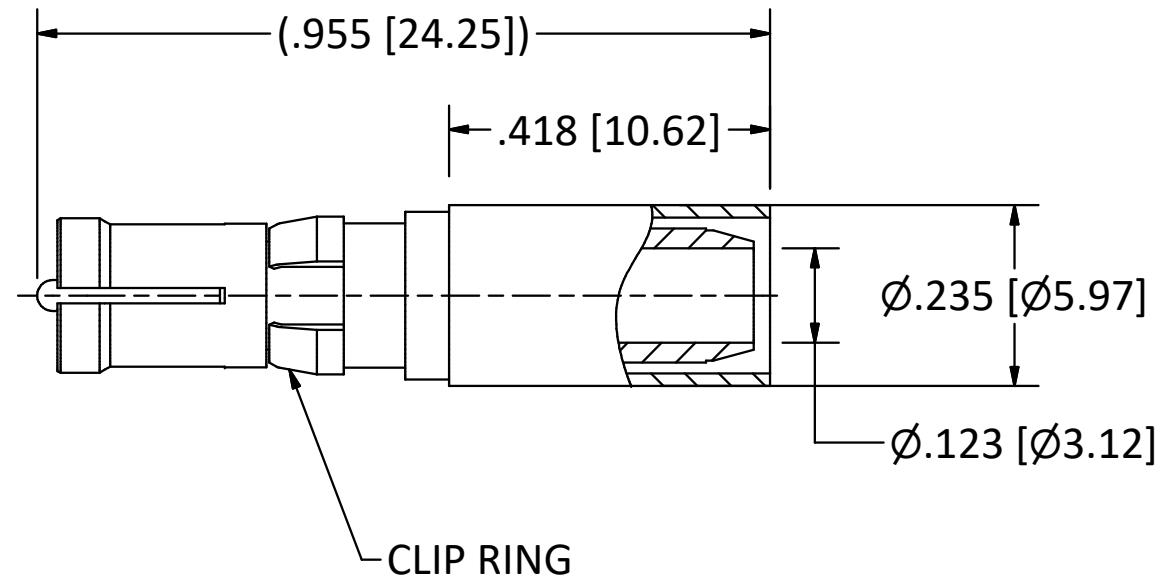
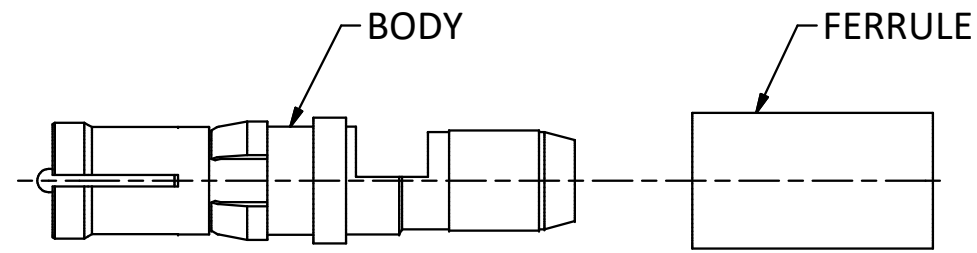

NOTES:

- 1. SPECIFICATIONS PER IDS 15J.
 - 2. FERRULE SHIPPED LOOSE.
 - 3. ACCOMMODATES RG-58, RG-141, OR RG-303 CABLE.
 - 4. MAGNETISM: <1.00000 mu.
 - 5. CRIMP USING .213 HEX DIE (M22520/5-05).
- HOUSING:** D-SUBMINIATURE, SIZE 8 CAVITY.

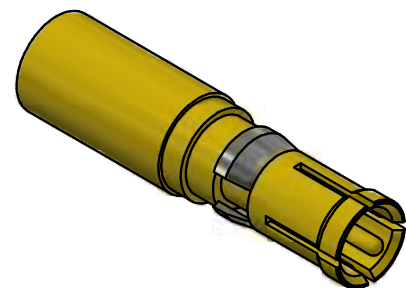

SCALE 2.5 : 1

REV.	DESCRIPTION	DATE	BY
E	ECN 6878	1/24/03	HN
D	ECN 5967	3/29/01	HN
C	ECN 3336	2/14/96	HN

This drawing embodies a proprietary design of The Phoenix Company of Chicago, Inc., Naugatuck, CT 06770. All design, manufacturing, reproduction, use, sale, and other rights regarding the same are expressly reserved. The information in this drawing may be covered completely or in part by patents and/or patents pending.

WARNING - THIS DOCUMENT CONTAINS TECHNICAL DATA WHOSE EXPORT IS RESTRICTED BY THE ARMS EXPORT CONTROL ACT (TITLE 22, U.S.C., SEC 2751, ET. SEQ.) OR THE EXPORT ADMINISTRATION ACT OF 1979, AS AMENDED, TITLE 50, U.S.C., APP 2401 ET SEQ. VIOLATIONS OF THESE EXPORT LAWS ARE SUBJECT TO SEVERE CRIMINAL PENALTIES. DISSEMINATE IN ACCORDANCE WITH PROVISIONS OF DOD DIRECTIVE 5230.25.

Filename: ver2\Autodesk Inventor Data Base\Assemblies\15 Series\15-1080-1201J-CU.idw		
UNLESS OTHERWISE SPECIFIED, PHOENIX WORKMANSHIP STANDARDS APPLY DIMENSIONS IN INCHES OR (METRIC) DO NOT SCALE PRINTS TOLERANCES ARE: FRACTIONS: ± 1/64 DECIMALS: .XX ± .01 .XXX ± .003 ANGLES: ± 1/2'	APPROVALS	DATE
	DRAWN HN	4/19/1978
	CHECKED HN	4/19/1978
	QA	
	MFG	
ENGINEER HN	4/19/1978	
APPROVED HN	4/19/1978	

The PHOENIX Company of Chicago, Inc.					
22 GREAT HILL RD., NAUGATUCK, CT 06770 WWW.PHOENIXOFCHICAGO.COM PHONE: (800) 323-9562 FAX:(630) 206-1801					
TITLE PDM JACK, CRIMP TERMINATION					
SIZE B	FSCM 58167	DWG NO 15-1080-1201J	REV E	PLATING OPT.	
SCALE 4 : 1	F.S.R. #	SHEET 1	OF 1		

4

3

2

1