

4

3

2

1

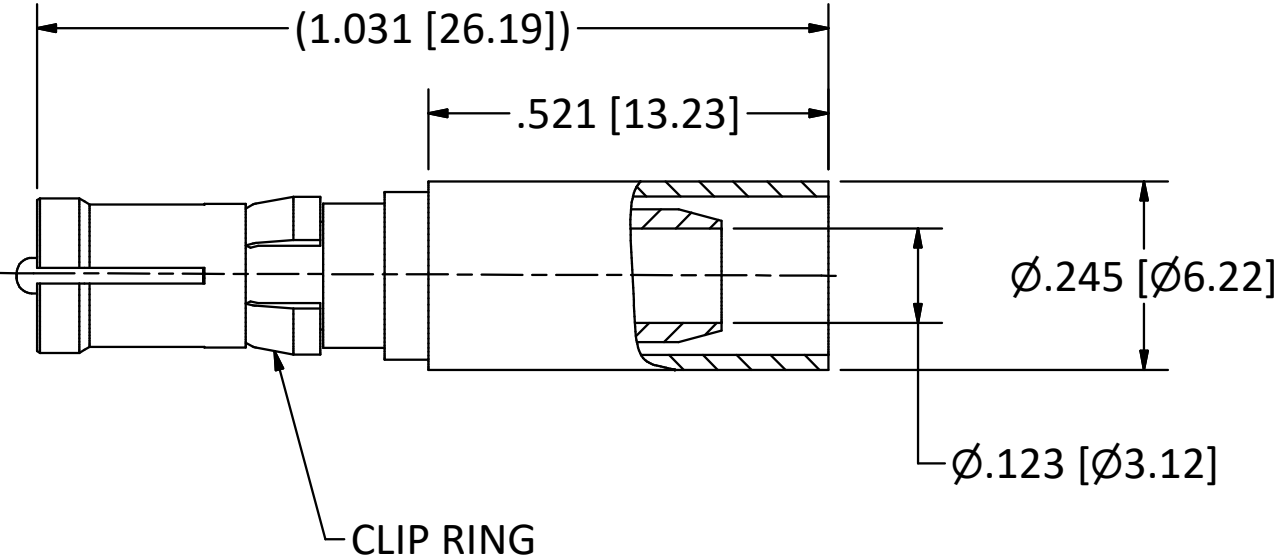
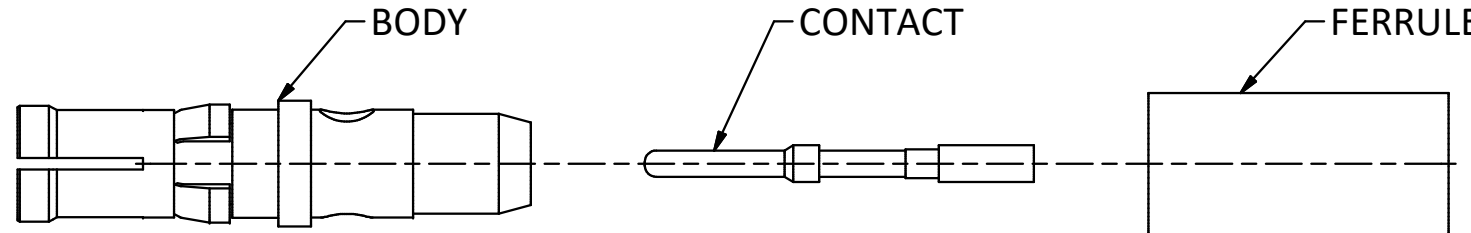

- NOTES:
1. SPECIFICATIONS PER IDS-15.
 2. FERRULE AND CONTACT SHIPPED LOOSE.
 3. ACCOMMODATES RG-58, RG-141, OR RG-303 CABLE.
 4. CRIMP USING .213 HEX DIE (M22520/5-05).
- HOUSING:** D-SUBMINIATURE, SIZE 8 CAVITY.

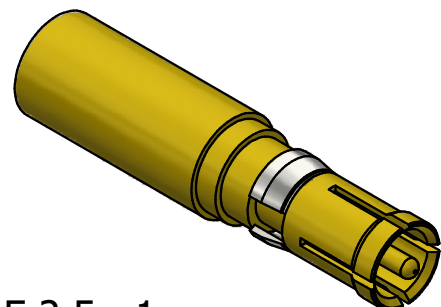

SCALE 2.5 : 1

D	PER ECN 1811	9/24/97	HN
C	PER ECN 1471	7/2/90	HN
B	PER ECN 1384	11/15/90	YT
A	PER ECN 1272	2/11/89	YT
REV	DESCRIPTION	DATE	BY

This drawing embodies a proprietary design of The Phoenix Company of Chicago, Inc., Naugatuck, CT 06770. All design, manufacturing, reproduction, use, sale, and other rights regarding the same are expressly reserved. The information in this drawing may be covered completely or in part by patents and/or patents pending.

WARNING - THIS DOCUMENT CONTAINS TECHNICAL DATA WHOSE EXPORT IS RESTRICTED BY THE ARMS EXPORT CONTROL ACT (TITLE 22, U.S.C., SEC 2751, ET. SEQ.) OR THE EXPORT ADMINISTRATION ACT OF 1979, AS AMENDED, TITLE 50, U.S.C., APP 2401 ET SEQ. VIOLATIONS OF THESE EXPORT LAWS ARE SUBJECT TO SEVERE CRIMINAL PENALTIES. DISSEMINATE IN ACCORDANCE WITH PROVISIONS OF DOD DIRECTIVE 5230.25.

Filename: \Autodesk Inventor Data Base\Assemblies\78 Series\78-1080-0670-CU-Layout for C Sized Drawing.idw		
UNLESS OTHERWISE SPECIFIED, PHOENIX WORKMANSHIP STANDARDS APPLY DIMENSIONS IN INCHES OR (METRIC) DO NOT SCALE PRINTS TOLERANCES ARE: FRACTIONS: ± 1/64 DECIMALS: .XX ± .01 .XXX ± .003 ANGLES: ± 1/2°	APPROVALS	DATE
	DRAWN YT	9/20/1988
	CHECKED HN	9/20/1988
	QA	
	MFG	
	ENGINEER HN	9/20/1988
APPROVED HN	9/20/1988	

The PHOENIX Company of Chicago, Inc.					
22 GREAT HILL RD., NAUGATUCK, CT 06770 WWW.PHOENIXOFCHICAGO.COM PHONE: (800) 323-9562 FAX:(630) 206-1801					
TITLE PDM RECEPTACLE, DOUBLE-CRIMP TERMINATION					
SIZE B	FSCM 58167	DWG NO 15-1090-1201	REV D	PLATING OPT. C, D	
SCALE	2.5 : 1	F.S.R. #		SHEET	1 OF 1

4

3

2

1