

CABLE ASSEMBLY PROCEDURE	
P/N	15-1090-2202
PAGE 1 OF 1	DATE: 01/12/99
DRAWN: JEM	APPROVED: HN
FOR USE WITH S86208 & TFLEX130-100 CABLES	

PALCO
CONNECTOR

22 GREAT HILL ROAD, NAUGATUCK, CT. 06770
PHONE: (203) 729-9090 FAX: (203) 723-1794

REV	DESCRIPTION	DATE	APPR
A	REL. ECN 4871	01/12/99	HN
B	PER ECN 4900	01/27/99	HN
D	PER ECN 9380	05/16/08	JEM
E	PER ECN 10530	08/17/10	JEM

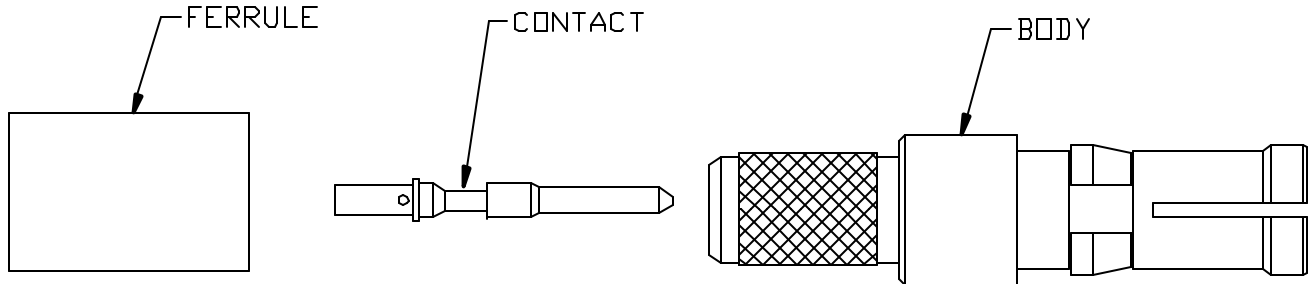

STEP 1
TRIM CABLE TO DIMENSIONS SHOWN.
TIN CENTER CONDUCTOR TO ϕ .038 MAX.
SLIDE FERRULE OVER CABLE.

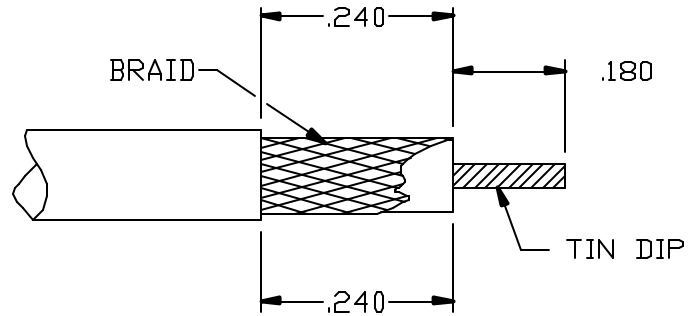

STEP 2
PLACE CONTACT ONTO
CENTER CONDUCTOR OF
CABLE LOCATED AS SHOWN
AND CRIMP INTO POSITION
USING DANIELS FT8 CRIMPER,
SETTING 3 FOR S86208 AND SETTING 2 FOR TFLX130-100 CABLES.
PALCO POSITIONER T 0753.
ROTATE DIELECTRIC TO FLAIR BRAID.

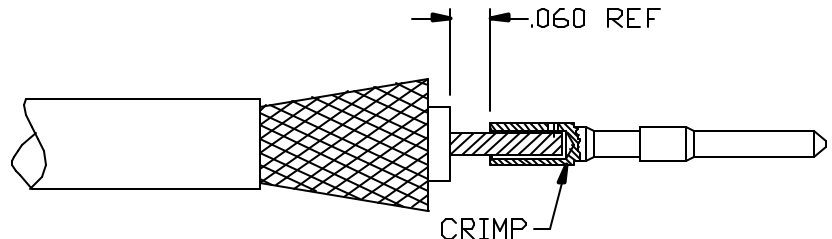

STEP 3
SLIDE BODY ONTO PREPARED CABLE,
OVER DIELECTRIC AND UNDER THE
BRAID. TEST SNAP FIT.
SLIDE FERRULE UP AGAINST
SHOULDER OF BODY AND CRIMP
USING .178 HEX DIE (M22520/5-05).

