

4

3

2

1

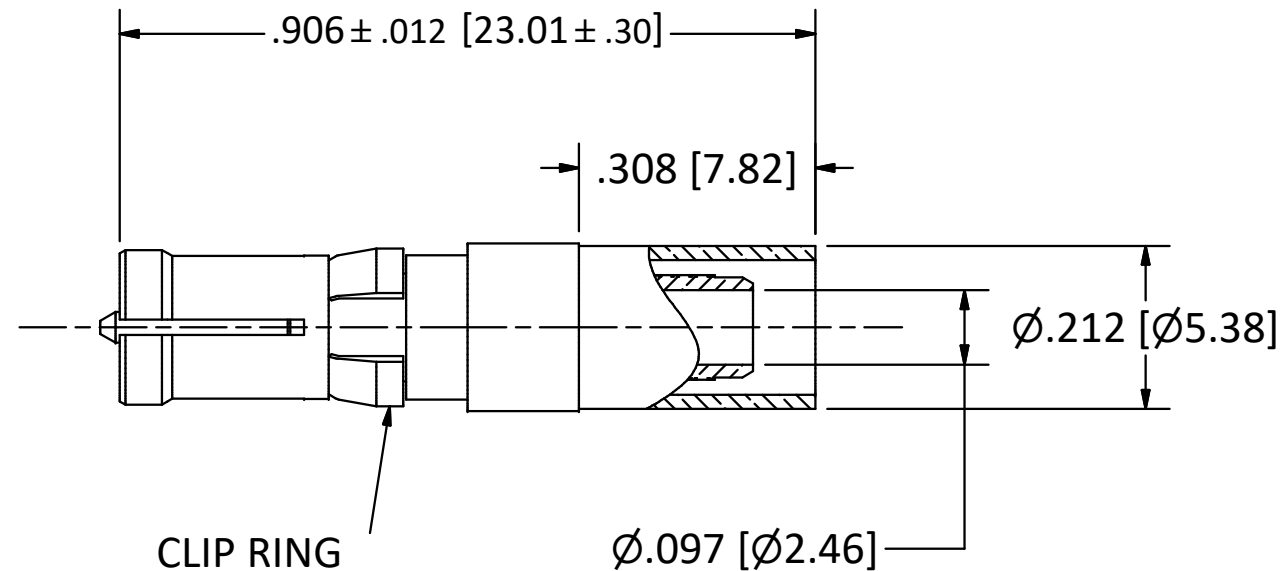
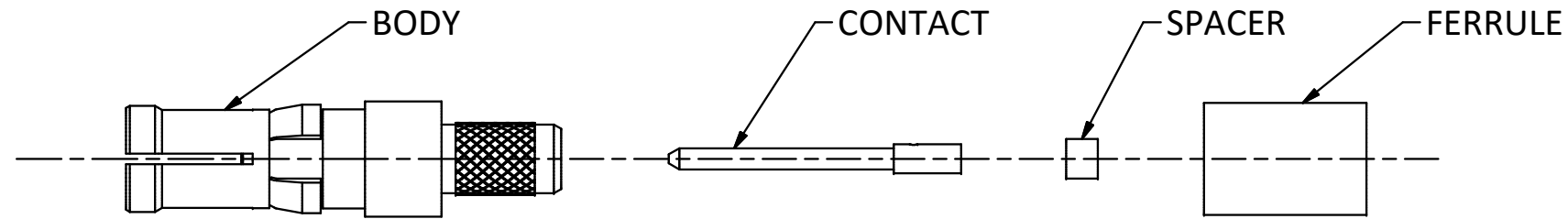

NOTES:

1. SPECIFICATIONS PER IDS-15.
 2. CONTACT, FERRULE, AND SPACER SHIPPED LOOSE.
 3. FOR LIMITED USE WITH PIC S86208 AND TFLX130-100 EMTEQ CABLES.
 4. CRIMP CENTER CONTACT USING DANIELS 'AFM8' CRIMPER AND 'K2160' POSITIONER
 - *SETTING #8 FOR S86208 CABLE AND
 - *SETTING #7 FOR TFLX130-100 CABLE.
 5. CRIMP FERRULE WITH .178 HEX DIE (M22520/5-05).
- HOUSING:** D-SUBMINIATURE, SIZE 8 CAVITY.

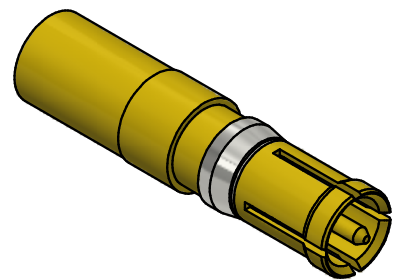

SCALE 2.5 : 1

| REV. | DESCRIPTION | DATE | APPR. |
|------|---------------|------------|-------|
| G | PER ECN 14435 | 6/24/2024 | SPS |
| F | PER ECN 14260 | 6/27/2023 | SPS |
| E | PER ECN 10530 | 08/17/2010 | HN |
| D | PER ECN 9380 | 05/16/2008 | HN |
| C | PER ECN 5090 | 06/07/1999 | EY |
| B | PER ECN 4900 | 01/27/1999 | EY |
| A | PER ECN 4871 | 01/19/1999 | EY |

This drawing embodies a proprietary design of The Phoenix Company of Chicago, Inc., Naugatuck, CT 06770. All design, manufacturing, reproduction, use, sale, and other rights regarding the same are expressly reserved. The information in this drawing may be covered completely or in part by patents and/or patents pending.

WARNING - THIS DOCUMENT CONTAINS TECHNICAL DATA WHOSE EXPORT IS RESTRICTED BY THE ARMS EXPORT CONTROL ACT (TITLE 22, U.S.C., SEC 2751, ET. SEQ.) OR THE EXPORT ADMINISTRATION ACT OF 1979, AS AMENDED, TITLE 50, U.S.C., APP 2401 ET SEQ. VIOLATIONS OF THESE EXPORT LAWS ARE SUBJECT TO SEVERE CRIMINAL PENALTIES. DISSEMINATE IN ACCORDANCE WITH PROVISIONS OF DOD DIRECTIVE 5230.25.

| | | |
|---|----------------|-----------|
| UNLESS OTHERWISE SPECIFIED, PHOENIX WORKMANSHIP STANDARDS APPLY DIMENSIONS IN INCHES OR (METRIC) DO NOT SCALE PRINTS TOLERANCES ARE: FRACTIONS: ± 1/64 DECIMALS: .XX ± .01 .XXX ± .003 ANGLES: ± 1/2° | APPROVALS | DATE |
| | DRAWN EY | 1/19/1999 |
| | CHECKED JEM | 1/19/1999 |
| | QA | |
| | MFG | |
| | ENGINEER HN | 1/19/1999 |
| APPROVED HN | 1/19/1999 | |

The PHOENIX Company of Chicago, Inc.
 22 GREAT HILL RD., NAUGATUCK, CT 06770
 WWW.PHOENIXOFCHICAGO.COM
 PHONE: (800) 323-9562 FAX:(630) 206-1801

| | | | | | |
|--|---------------|-------------------------------|----------|----------------------------|--|
| TITLE PDM RECEPTACLE, DOUBLE-CRIMP TERMINATION | | | | | |
| SIZE B | FSCM 58167 | DWG NO 15-1090-2202 | REV G | PLATING OPT. A, B, C, D | |
| SCALE 3 : 1 | F.S.R. # | SHEET 1 | OF 1 | | |

4

3

2

1