

4

3

2

1

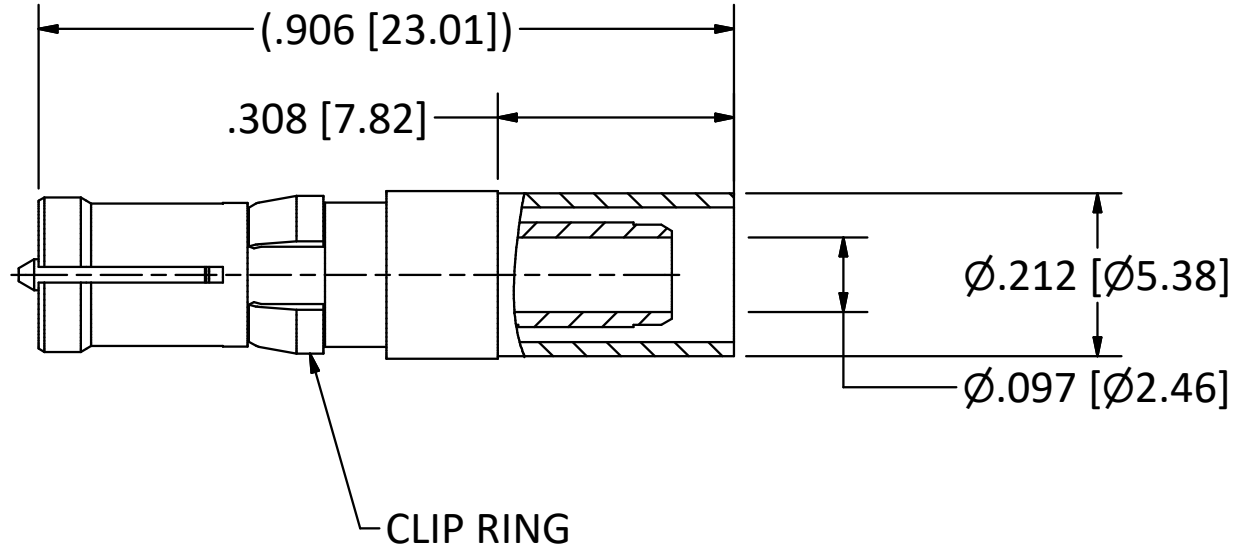
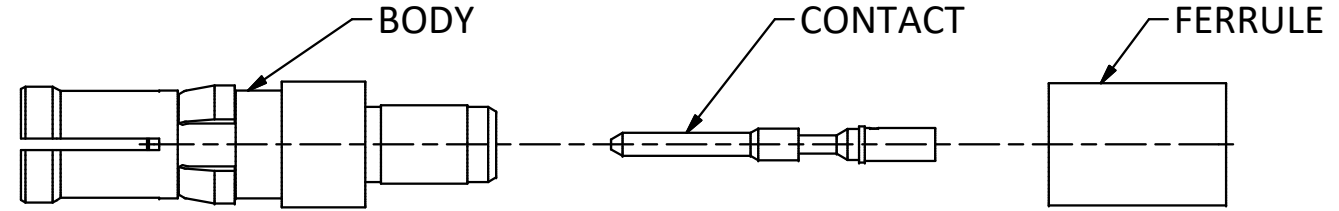

- NOTES:
1. SPECIFICATIONS PER IDS-15.
 2. FERRULE AND CONTACT SHIPPED LOOSE.
 3. ACCOMMODATES EMTEQ, TFLX130-100, OR PIC S86208 CABLE.
 4. CRIMP WITH .178 HEX DIE (M22520/5-05).
- HOUSING:** D-SUBMINIATURE, SIZE 8 CAVITY.

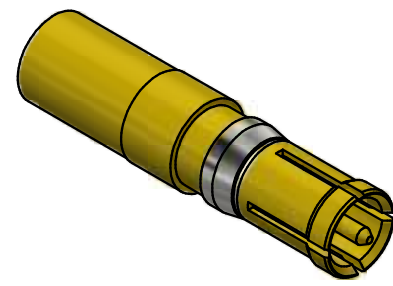

SCALE 2.5 : 1

REV	DESCRIPTION	DATE	BY
E	PER ECN 10530	8/17/10	JEM
D	PER ECN 9380	5/18/08	JEM
C	PER ECN 5090	6/7/99	HN
B	PER ECN 4900	1/27/99	HN
A	PER ECN 4871	1/19/99	HN

This drawing embodies a proprietary design of The Phoenix Company of Chicago, Inc., Naugatuck, CT 06770. All design, manufacturing, reproduction, use, sale, and other rights regarding the same are expressly reserved. The information in this drawing may be covered completely or in part by patents and/or patents pending.

WARNING - THIS DOCUMENT CONTAINS TECHNICAL DATA WHOSE EXPORT IS RESTRICTED BY THE ARMS EXPORT CONTROL ACT (TITLE 22, U.S.C., SEC 2751, ET. SEQ.) OR THE EXPORT ADMINISTRATION ACT OF 1979, AS AMENDED, TITLE 50, U.S.C., APP 2401 ET SEQ. VIOLATIONS OF THESE EXPORT LAWS ARE SUBJECT TO SEVERE CRIMINAL PENALTIES. DISSEMINATE IN ACCORDANCE WITH PROVISIONS OF DOD DIRECTIVE 5230.25.

Filename: ver2\Autodesk Inventor Data Base\Assemblies\15 Series\15-1090-2202-CU.idw		
UNLESS OTHERWISE SPECIFIED, PHOENIX WORKMANSHIP STANDARDS APPLY DIMENSIONS IN INCHES OR (METRIC) DO NOT SCALE PRINTS TOLERANCES ARE: FRACTIONS: ± 1/64 DECIMALS: .XX ± .01 .XXX ± .003 ANGLES: ± 1/2°	APPROVALS	DATE
	DRAWN EY	1/19/1999
	CHECKED JEM	1/19/1999
	QA	
	MFG	
	ENGINEER EY	1/19/1999
APPROVED YEM	1/19/1999	

The PHOENIX Company of Chicago, Inc.
 22 GREAT HILL RD., NAUGATUCK, CT 06770
 WWW.PHOENIXOFCHICAGO.COM
 PHONE: (800) 323-9562 FAX:(630) 206-1801

TITLE
PDM RECEPTACLE, DOUBLE-CRIMP TERMINATION

SIZE B	FSCM 58167	DWG NO 15-1090-2202	REV E	PLATING OPT. A, B, C, D
SCALE 4 : 1		F.S.R. #	SHEET 1 OF 1	

4

3

2

1