

4

3

2

1

B

B

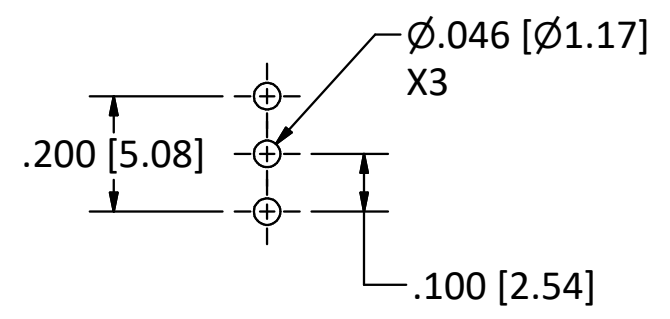
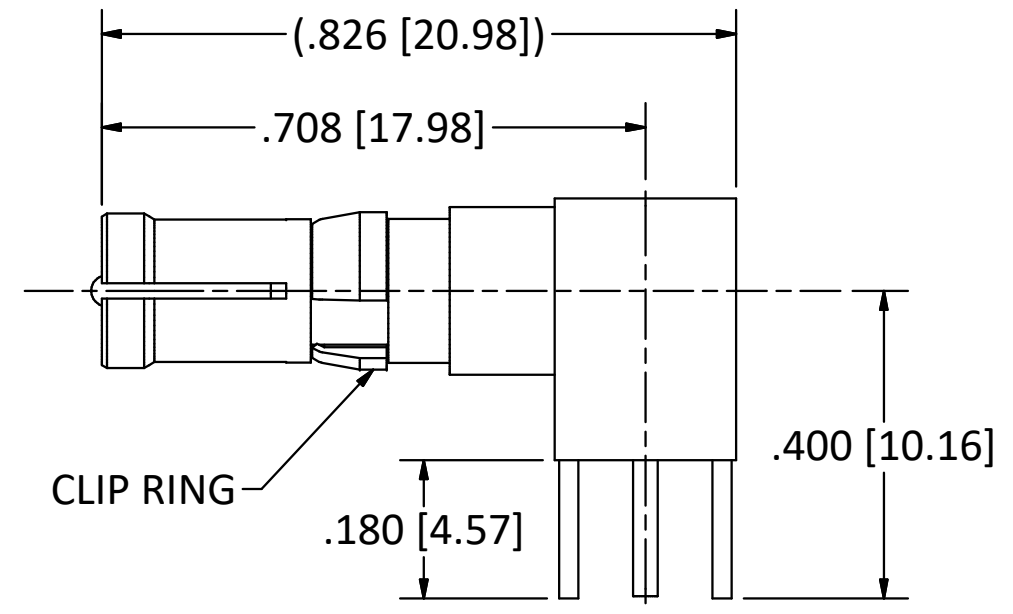
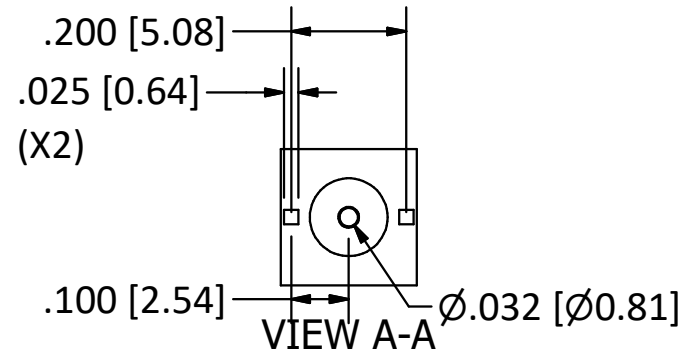

NOTES:
 1. SPECIFICATIONS PER IDS-15J.
 2. MAGNETISM: <1.00000 mu.
HOUSING: D-SUBMINIATURE, SIZE 8 CAVITY, SHELL SIZE A, B, C, & E.

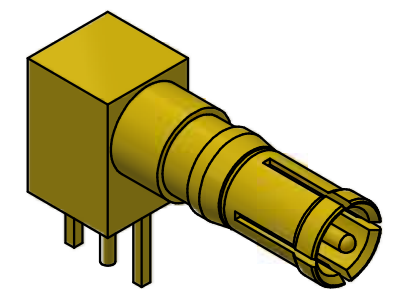

SCALE 2.5 : 1

This drawing embodies a proprietary design of The Phoenix Company of Chicago, Inc., Naugatuck, CT 06770. All design, manufacturing, reproduction, use, sale, and other rights regarding the same are expressly reserved. The information in this drawing may be covered completely or in part by patents and/or patents pending.				WARNING - THIS DOCUMENT CONTAINS TECHNICAL DATA WHOSE EXPORT IS RESTRICTED BY THE ARMS EXPORT CONTROL ACT (TITLE 22, U.S.C., SEC 2751, ET. SEQ.) OR THE EXPORT ADMINISTRATION ACT OF 1979, AS AMENDED, TITLE 50, U.S.C., APP 2401 ET SEQ. VIOLATIONS OF THESE EXPORT LAWS ARE SUBJECT TO SEVERE CRIMINAL PENALTIES. DISSEMINATE IN ACCORDANCE WITH PROVISIONS OF DOD DIRECTIVE 5230.25.			Filename: ver2\Autodesk Inventor Data Base\Assemblies\15 Series\15-3450-73J-CU.idw			The PHOENIX Company of Chicago, Inc. 22 GREAT HILL RD., NAUGATUCK, CT 06770 WWW.PHOENIXOFCHICAGO.COM PHONE: (800) 323-9562 FAX:(630) 206-1801		
							UNLESS OTHERWISE SPECIFIED, PHOENIX WORKMANSHIP STANDARDS APPLY DIMENSIONS IN INCHES OR (METRIC) DO NOT SCALE PRINTS TOLERANCES ARE: FRACTIONS: ± 1/64 DECIMALS: .XX ± .01 .XXX ± .003 ANGLES: ± 1/2°					
H PER ECN 7893 REV. DESCRIPTION		03/30/05 DATE		JEM BY		SIZE B FSCM 58167		DWG NO 15-3450-73J		REV H	PLATING OPT.	
							SCALE 4 : 1		F.S.R. #		SHEET 1 OF 1	

4

3

2

1

A

A