

4

3

2

1

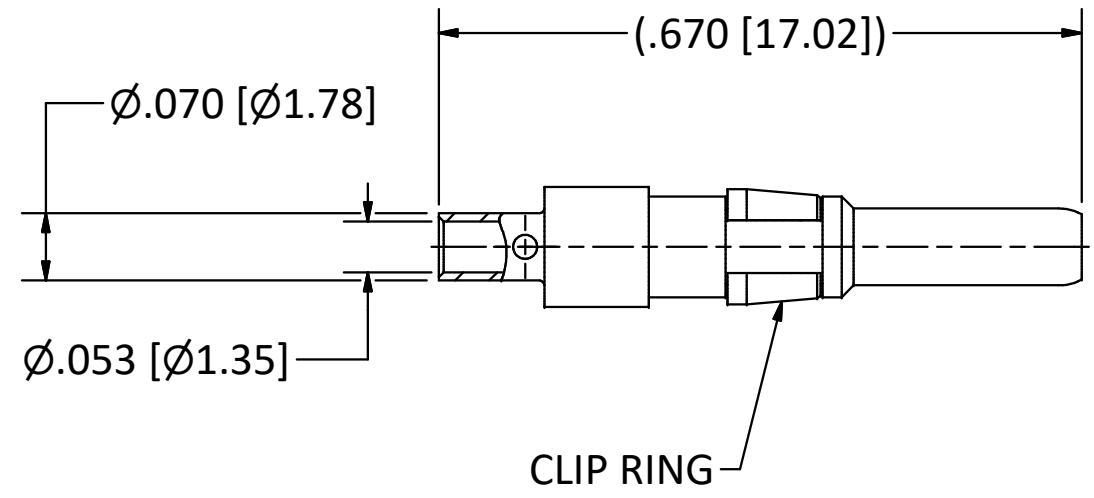
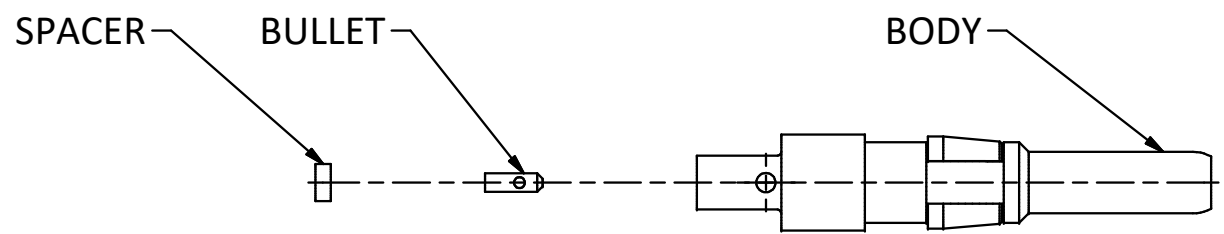

- NOTES:
1. SPECIFICATIONS PER IDS-156.
 2. BULLET AND SPACER SHIPPED LOOSE.
 3. ACCOMMODATES RG-178, RG-196, OR 1.37mm CABLE.
- HOUSING:** PRC AND CUSTOM, SIZE 16 CAVITY.

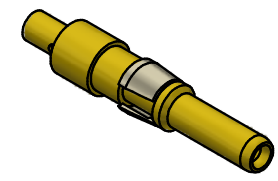

SCALE 2.5 : 1

<table border="1"> <tr> <td>B</td> <td>PER ECN 13816</td> <td>7/27/20</td> <td>JEM</td> </tr> <tr> <td>A</td> <td>PER ECN 12367</td> <td>9/19/16</td> <td>RMB</td> </tr> <tr> <td>01</td> <td>PRELIMINARY</td> <td>6/15/16</td> <td>RMB</td> </tr> <tr> <td>REV</td> <td>DESCRIPTION</td> <td>DATE</td> <td>BY</td> </tr> </table>				B	PER ECN 13816	7/27/20	JEM	A	PER ECN 12367	9/19/16	RMB	01	PRELIMINARY	6/15/16	RMB	REV	DESCRIPTION	DATE	BY	<p>This drawing embodies a proprietary design of The Phoenix Company of Chicago, Inc., Naugatuck, CT 06770. All design, manufacturing, reproduction, use, sale, and other rights regarding the same are expressly reserved. The information in this drawing may be covered completely or in part by patents and/or patents pending.</p>		<p>WARNING - THIS DOCUMENT CONTAINS TECHNICAL DATA WHOSE EXPORT IS RESTRICTED BY THE ARMS EXPORT CONTROL ACT (TITLE 22, U.S.C., SEC 2751, ET. SEQ.) OR THE EXPORT ADMINISTRATION ACT OF 1979, AS AMENDED, TITLE 50, U.S.C., APP 2401 ET SEQ. VIOLATIONS OF THESE EXPORT LAWS ARE SUBJECT TO SEVERE CRIMINAL PENALTIES. DISSEMINATE IN ACCORDANCE WITH PROVISIONS OF DOD DIRECTIVE 5230.25.</p>		<p>Filename: ver2\Autodesk Inventor Data Base\Assemblies\156 Series\156-0202-0400-CU.idw</p> <p>UNLESS OTHERWISE SPECIFIED, PHOENIX WORKMANSHIP STANDARDS APPLY DIMENSIONS IN INCHES OR (METRIC)</p> <p>DO NOT SCALE PRINTS</p> <p>TOLERANCES ARE: FRACTIONS: ± 1/64 DECIMALS: .XX ± .01 .XXX ± .003 ANGLES: ± 1/2°</p>		<table border="1"> <tr> <th>APPROVALS</th> <th>DATE</th> </tr> <tr> <td>DRAWN JEM</td> <td>6/15/2016</td> </tr> <tr> <td>CHECKED RMB</td> <td>6/15/2016</td> </tr> <tr> <td>QA</td> <td></td> </tr> <tr> <td>MFG</td> <td></td> </tr> <tr> <td>ENGINEER JEM</td> <td>6/15/2016</td> </tr> <tr> <td>APPROVED RMB</td> <td>6/15/2016</td> </tr> </table>		APPROVALS	DATE	DRAWN JEM	6/15/2016	CHECKED RMB	6/15/2016	QA		MFG		ENGINEER JEM	6/15/2016	APPROVED RMB	6/15/2016	<p>The PHOENIX Company of Chicago, Inc.</p> <p>22 GREAT HILL RD., NAUGATUCK, CT 06770 WWW.PHOENIXOFCHICAGO.COM</p> <p>PHONE: (800) 323-9562 FAX:(630) 206-1801</p>			
B	PER ECN 13816	7/27/20	JEM																																										
A	PER ECN 12367	9/19/16	RMB																																										
01	PRELIMINARY	6/15/16	RMB																																										
REV	DESCRIPTION	DATE	BY																																										
APPROVALS	DATE																																												
DRAWN JEM	6/15/2016																																												
CHECKED RMB	6/15/2016																																												
QA																																													
MFG																																													
ENGINEER JEM	6/15/2016																																												
APPROVED RMB	6/15/2016																																												
<p>TITLE</p> <p>PKZ® PLUG, DIRECT SOLDER TERMINATION</p>																																													
<p>SIZE</p> <p>B</p>		<p>FSCM</p> <p>58167</p>		<p>DWG NO</p> <p>156-0202-0400</p>		<p>REV</p> <p>B</p>	<p>PLATING OPT.</p> <p>A, C</p>																																						
<p>SCALE</p> <p>5 : 1</p>		<p>F.S.R. #</p>		<p>SHEET</p> <p>1 OF 1</p>																																									

4

3

2

1