

4

3

2

1

B

B

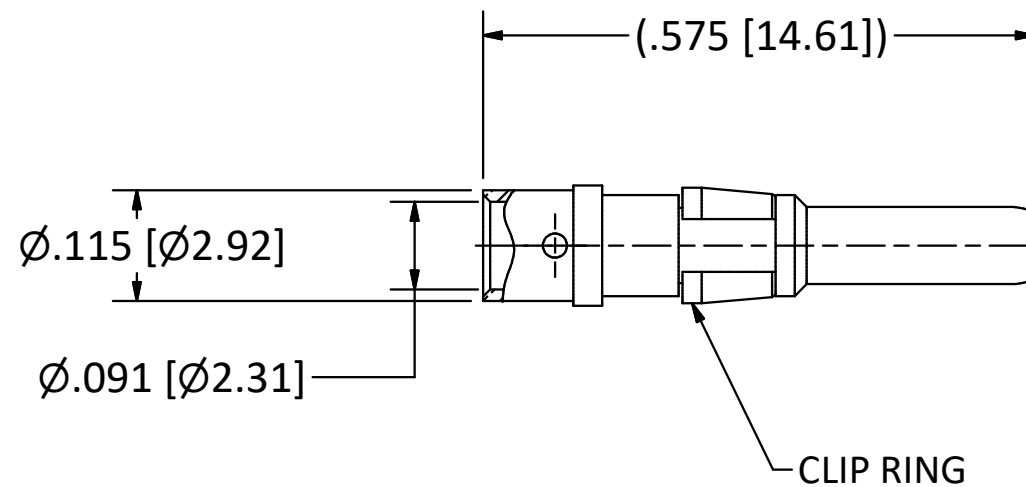

NOTES:

- 1. SPECIFICATIONS PER IDS-156.
- 2. ACCOMMODATES RG-405 (.086 SEMI-RIGID) OR EQUIVALENT FLEXIBLE CABLE.
- 3. ELECTRICAL RESULTS WHEN MATED TO 156 SERIES SIZE 16 PkZ® RECEPTACLE:
 - a) FREQUENCY: DC TO 50 GHz.
 - b) VSWR: 1.40:1 (MAX) UP TO 40 GHz.

HOUSING: PRC AND CUSTOM, SIZE 16 CAVITY.

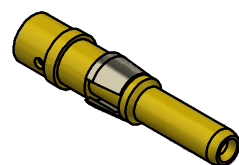

SCALE 2.5 : 1

4

3

2

1

A

A

				<p>This drawing embodies a proprietary design of The Phoenix Company of Chicago, Inc., Naugatuck, CT 06770. All design, manufacturing, reproduction, use, sale, and other rights regarding the same are expressly reserved. The information in this drawing may be covered completely or in part by patents and/or patents pending.</p>	Filename: ver2\Autodesk Inventor Data Base\Assemblies\156 Series\156-0202-0860-CU.idw		The PHOENIX Company of Chicago, Inc. 22 GREAT HILL RD., NAUGATUCK, CT 06770 WWW.PHOENIXOFCHICAGO.COM PHONE: (800) 323-9562 FAX:(630) 206-1801					
					UNLESS OTHERWISE SPECIFIED, PHOENIX WORKMANSHIP STANDARDS APPLY DIMENSIONS IN INCHES OR (METRIC) DO NOT SCALE PRINTS TOLERANCES ARE: FRACTIONS: ± 1/64 DECIMALS: .XX ± .01 .XXX ± .003 ANGLES: ± 1/2°	APPROVALS DATE		TITLE PkZ® PLUG, DIRECT SOLDER TERMINATION				
						DRAWN JEM						11/21/2013
					CHECKED RMB		6/4/2015		SIZE FSCM DWG NO B 58167 156-0202-0860			
					QA		MFG					
					ENGINEER JEM		11/21/2013		REV PLATING OPT. A, B			
					APPROVED RMB		6/4/2015		SCALE 5 : 1 F.S.R. # SHEET 1 OF 1			
					32√							

REV	DESCRIPTION	DATE	BY
		11/10/2021	
H	PER ECN 13392	7/9/19	JEM
G	PER ECN 13274	3/26/19	JEM
F	PER ECN 13064	8/7/18	JEM
E	PER ECN 12710	11/22/17	JEM
D	PER ECN 12601	9/13/17	RMB
C	PER ECN 12225	10/2/15	JEM
B	PER ECN 12172	6/4/15	JEM
A	REL ECN 11877	3/28/14	JEM