

STEP 1
TRIM CABLE TO DIMENSIONS SHOWN
POINT CENTER CONDUCTOR.

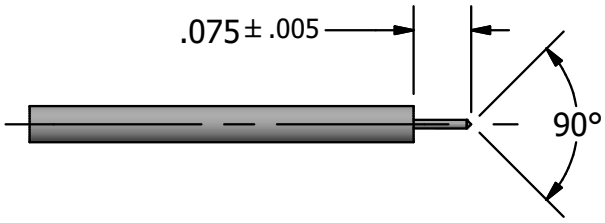

STEP 2
INSTALL SOLDER NUT ONTO CABLE
(UNTIL SOLDER NUT BOTTOMS OUT).
SOLDER TO CABLE AS SHOWN.
CLEAN SOLDER JOINT.

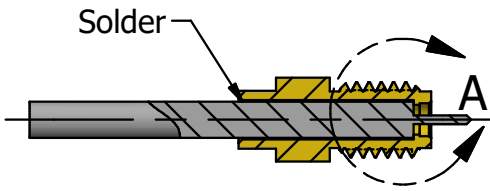

MEASURE **.052 ± .005**

LIMIT THE DIELECTRIC EXTRUSION TO THIS POINT

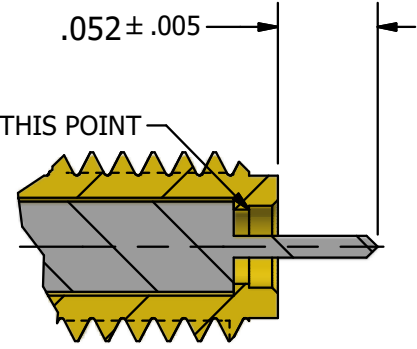

STEP 3
INSTALL SUPPORT BEAD ONTO CABLE
USING T3017P BY HAND (PRESS FIT)
AND ORIENT IT AS SHOWN.

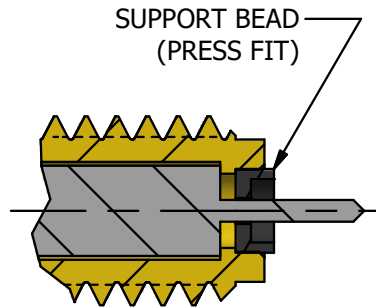
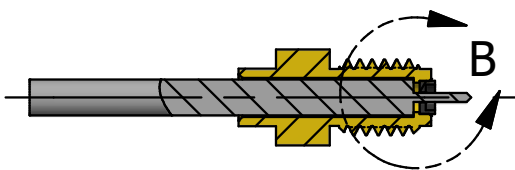

STEP 4
INSTALL BODY ONTO PREPARED CABLE
FROM STEP 3. TORQUE TO 60-70
INCH-OZS USING PALCO T650-112
WRENCH AND 7/64 TORQUE WRENCH.

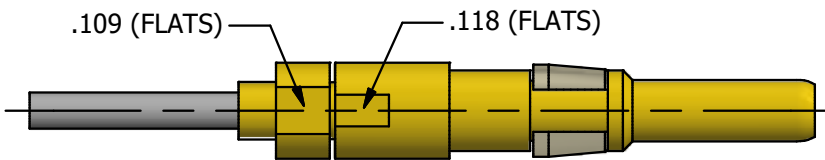

CAD DRAWING - NO MANUAL REVISIONS
filename:h-Palco-Phoenix\Palco_A-B-C_Sizes_11-26-2018.idw

WARNING - THIS DOCUMENT CONTAINS TECHNICAL DATA WHOSE EXPORT IS RESTRICTED BY THE ARMS EXPORT CONTROL ACT (TITLE 22, U.S.C., SEC 2751, ET. SEQ.) OR THE EXPORT ADMINISTRATION ACT OF 1979, AS AMENDED, TITLE 50, U.S.C., APP 2401 ET SEQ. VIOLATIONS OF THESE EXPORT LAWS ARE SUBJECT TO SEVERE CRIMINAL PENALTIES. DISSEMINATE IN ACCORDANCE WITH PROVISIONS OF DOD DIRECTIVE 5230.25.

MATERIAL: CATALOG ITEM				APPROVALS DRAWN SPS CHECKED JEM QA MFG ENGINEER SPS APPROVED JEM		DATE 12/03/2020 12/03/2020 12/03/2020 12/03/2020		<i>The PHOENIX Company of Chicago, Inc.</i> 22 GREAT HILL RD., NAUGATUCK, CT 06770 WWW.PHOENIXOFCHICAGO.COM			
				UNLESS OTHERWISE SPECIFIED, PHOENIX WORKMANSHIP STANDARDS APPLY. DIMENSIONS IN INCHES OR (METRIC) DO NOT SCALE PRINTS TOLERANCES ARE: FRACTIONS: ± 1/64 DECIMALS: .XX ± .01 .XXX ± .003 ANGLES: ± 1/2°		THE INFORMATION DISCLOSED IN THIS DOCUMENT IS CONFIDENTIAL AND PROPRIETARY TO PHOENIX CO. INC. AND MAY NOT BE USED FOR MANUFACTURE OR ANY OTHER PURPOSE WITHOUT THE WRITTEN CONSENT OF THE PHOENIX CO. OF CHICAGO INC.		TITLE CABLE ASSEMBLY PROCESS FOR 156-0302-0470/J			
F	PER ECN 13921	12/03/2020	JEM	SIZE	FSCM	DWG NO	REV	PLATING OPT.			
E	PER ECN 13857	9/24/2020	JEM	A	58167	156-0302-0470	F				
D	PER ECN 13046	05/07/2019	JEM	SCALE	F.S.R. #		SHEET 1 OF 1				
C	PER ECN 12304	5/3/2016	RMB								
B	ECN #12150	4/20/2015	R.M.B.								
A	REL. PER ECN 11794	11/11/2013	JEM								
REV.	DESCRIPTION	DATE	APPR.								