

4

3

2

1

B

B

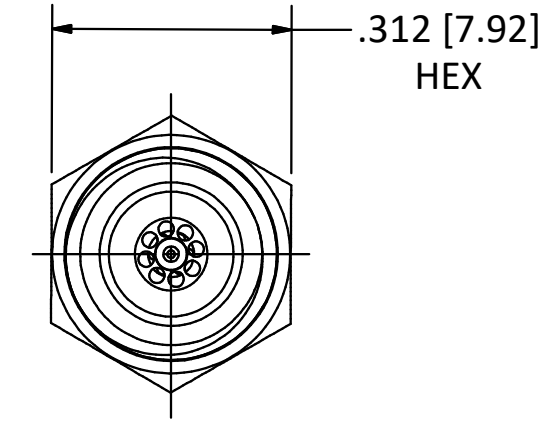
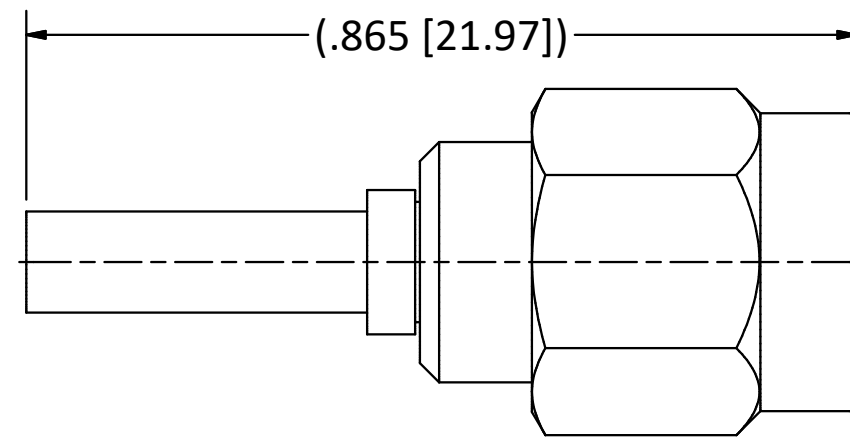

NOTES:
 1. SPECIFICATIONS PER IDS-156 AND IDS-2_4 (2.4mm).

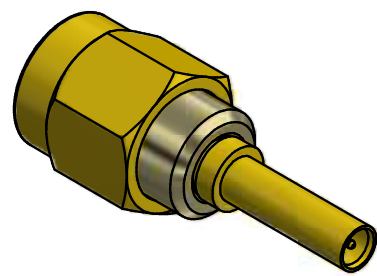

SCALE 2.5 : 1

4

3

2

1

A

A

<table border="1"> <tr> <td>A</td> <td>PER ECN 12722</td> <td>12/4/17</td> <td>SPS</td> </tr> <tr> <td>01</td> <td>PRELIMINARY</td> <td>1/10/17</td> <td>RMB</td> </tr> <tr> <td>REV</td> <td>DESCRIPTION</td> <td>DATE</td> <td>BY</td> </tr> </table>				A	PER ECN 12722	12/4/17	SPS	01	PRELIMINARY	1/10/17	RMB	REV	DESCRIPTION	DATE	BY	<p>This drawing embodies a proprietary design of The Phoenix Company of Chicago, Inc., Naugatuck, CT 06770. All design, manufacturing, reproduction, use, sale, and other rights regarding the same are expressly reserved. The information in this drawing may be covered completely or in part by patents and/or patents pending.</p>	<p>WARNING - THIS DOCUMENT CONTAINS TECHNICAL DATA WHOSE EXPORT IS RESTRICTED BY THE ARMS EXPORT CONTROL ACT (TITLE 22, U.S.C., SEC 2751, ET. SEQ.) OR THE EXPORT ADMINISTRATION ACT OF 1979, AS AMENDED, TITLE 50, U.S.C., APP 2401 ET SEQ. VIOLATIONS OF THESE EXPORT LAWS ARE SUBJECT TO SEVERE CRIMINAL PENALTIES. DISSEMINATE IN ACCORDANCE WITH PROVISIONS OF DOD DIRECTIVE 5230.25.</p>	Filename: ver2\Autodesk Inventor Data Base\Adaptors\1562_4\1562_4-1000-00-CU.idw		<p>The PHOENIX Company of Chicago, Inc. 22 GREAT HILL RD., NAUGATUCK, CT 06770 WWW.PHOENIXOFCHICAGO.COM PHONE: (800) 323-9562 FAX:(630) 206-1801</p>	
				A	PER ECN 12722	12/4/17	SPS														
01	PRELIMINARY	1/10/17	RMB																		
REV	DESCRIPTION	DATE	BY																		
UNLESS OTHERWISE SPECIFIED, PHOENIX WORKMANSHIP STANDARDS APPLY DIMENSIONS IN INCHES OR (METRIC) DO NOT SCALE PRINTS TOLERANCES ARE: FRACTIONS: ± 1/64 DECIMALS: .XX ± .01 .XXX ± .003 ANGLES: ± 1/2°		APPROVALS DRAWN CHECKED QA MFG ENGINEER APPROVED	DATE 1/10/2017 1/10/2017 1/10/2017 1/10/2017																		
				ADAPTER, PkZ® RECEPTACLE TO 2.4mm PLUG		SIZE B	FSCM 58167	DWG NO 1562_4-1000-00	REV A	PLATING OPT. G											
				SCALE 5 : 1		F.S.R. #		SHEET 1 OF 1													