

4

3

2

1

B

B

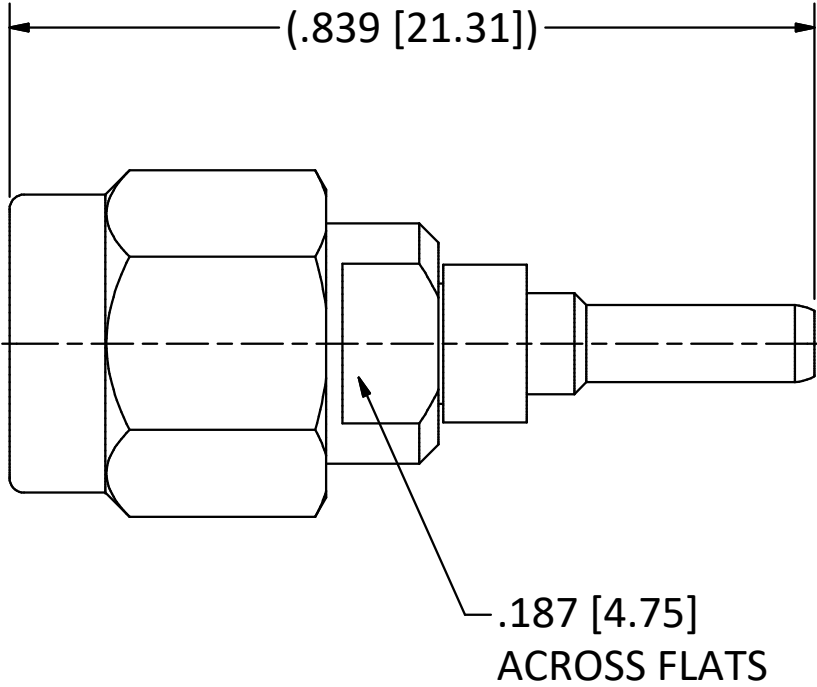
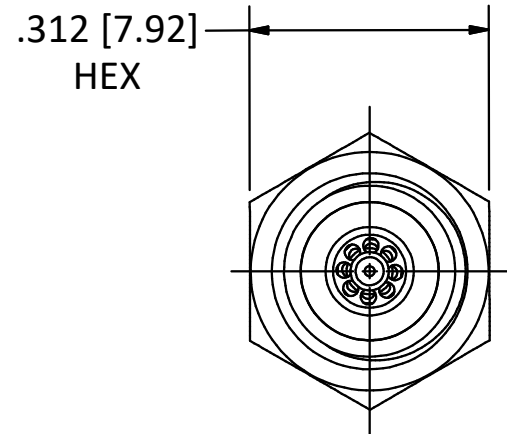

NOTES:  
1. SPECIFICATIONS PER IDS-156 AND IDS-2\_9 (2.92mm).

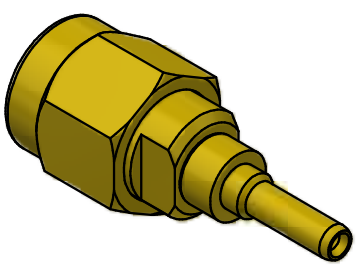

SCALE 2.5 : 1

REV	DESCRIPTION	DATE	BY
F	PER ECN 12558	8/2/17	JEM
E	PER ECN 12519	5/24/17	JEM
D	PER ECN 123181	10/25/16	RMB
C	PER ECN 12321	6/8/16	RMB
B	PER ECN 12138	1/31/15	JEM
A	ECN 11940	8/1/14	JEM

This drawing embodies a proprietary design of The Phoenix Company of Chicago, Inc., Naugatuck, CT 06770. All design, manufacturing, reproduction, use, sale, and other rights regarding the same are expressly reserved. The information in this drawing may be covered completely or in part by patents and/or patents pending.

WARNING - THIS DOCUMENT CONTAINS TECHNICAL DATA WHOSE EXPORT IS RESTRICTED BY THE ARMS EXPORT CONTROL ACT (TITLE 22, U.S.C., SEC 2751, ET. SEQ.) OR THE EXPORT ADMINISTRATION ACT OF 1979, AS AMENDED, TITLE 50, U.S.C., APP 2401 ET SEQ. VIOLATIONS OF THESE EXPORT LAWS ARE SUBJECT TO SEVERE CRIMINAL PENALTIES. DISSEMINATE IN ACCORDANCE WITH PROVISIONS OF DOD DIRECTIVE 5230.25.

Filename: \\Autodesk Inventor Data Base\Assemblies\78 Series\78-1080-0670-CU-Layout for C Sized Drawing.idw		
UNLESS OTHERWISE SPECIFIED, PHOENIX WORKMANSHIP STANDARDS APPLY DIMENSIONS IN INCHES OR (METRIC)	APPROVALS	DATE
	DRAWN B. KNOTT	7/24/2014
DO NOT SCALE PRINTS	CHECKED JEM	7/24/2014
	QA	
TOLERANCES ARE: FRACTIONS: ± 1/64 DECIMALS: .XX ± .01 .XXX ± .003 ANGLES: ± 1/2°	MFG	
	ENGINEER B. KNOTT	7/24/2014
	APPROVED JEM	7/24/2014

<b>The PHOENIX Company of Chicago, Inc.</b>					
22 GREAT HILL RD., NAUGATUCK, CT 06770 WWW.PHOENIXOFCHICAGO.COM PHONE: (800) 323-9562 FAX:(630) 206-1801					
TITLE <b>ADAPTER, PkZ® PLUG TO 2.92mm PLUG</b>					
SIZE <b>B</b>	FSCM 58167	DWG NO <b>1562_9-0000-00</b>	REV F	PLATING OPT. G, P	
SCALE	5: 1	F.S.R. #	SHEET	1	OF 1

4

3

2

1

A

A