

4

3

2

1

B

B

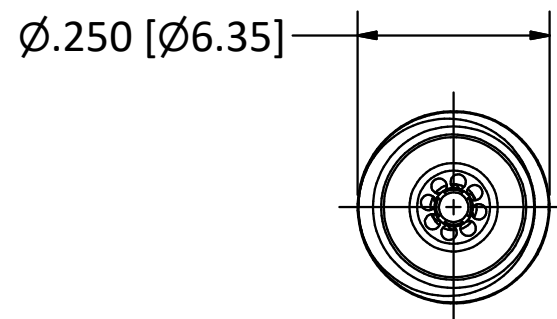
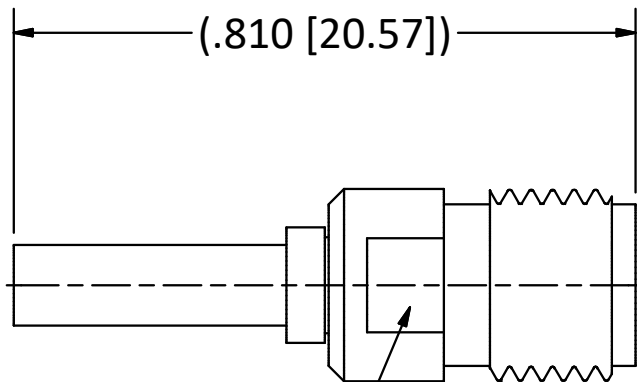

NOTES:
 1. SPECIFICATIONS PER IDS-156 AND IDS-2_9 (2.92mm).

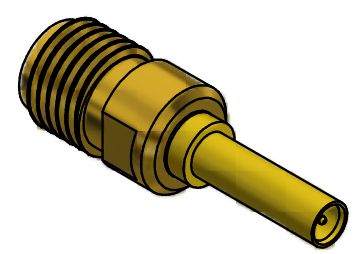

SCALE 2.5: 1

4

3

2

1

A

A

| This drawing embodies a proprietary design of The Phoenix Company of Chicago, Inc., Naugatuck, CT 06770. All design, manufacturing, reproduction, use, sale, and other rights regarding the same are expressly reserved. The information in this drawing may be covered completely or in part by patents and/or patents pending. | | | | WARNING - THIS DOCUMENT CONTAINS TECHNICAL DATA WHOSE EXPORT IS RESTRICTED BY THE ARMS EXPORT CONTROL ACT (TITLE 22, U.S.C., SEC 2751, ET. SEQ.) OR THE EXPORT ADMINISTRATION ACT OF 1979, AS AMENDED, TITLE 50, U.S.C., APP 2401 ET SEQ. VIOLATIONS OF THESE EXPORT LAWS ARE SUBJECT TO SEVERE CRIMINAL PENALTIES. DISSEMINATE IN ACCORDANCE WITH PROVISIONS OF DOD DIRECTIVE 5230.25. | | Filename: \\Autodesk Inventor Data Base\Assemblies\78 Series\78-1080-0670-CU-Layout for C Sized Drawing.idw | | The PHOENIX Company of Chicago, Inc. 22 GREAT HILL RD., NAUGATUCK, CT 06770 WWW.PHOENIXOFCHICAGO.COM PHONE: (800) 323-9562 FAX:(630) 206-1801 | | | | | | | | | | | | | | | | | | | | | | | | | | | | | | | |
|--|---------------|---------------|-------------|---|----|---|---------------|--|-----|-----------|---------------|-------------------|-----------|----------------|---------------|----------|-----|-----|---------------|----------------------|-----------|-----------------|---------------|---|-----|---|-----------|--------|-----|------------------|--|---------------|--|---------------------------------|--|----------|--|----------------------|--|
| | | | | | | UNLESS OTHERWISE SPECIFIED, PHOENIX WORKMANSHIP STANDARDS APPLY DIMENSIONS IN INCHES OR (METRIC) DO NOT SCALE PRINTS TOLERANCES ARE: FRACTIONS: ± 1/64 DECIMALS: .XX ± .01 .XXX ± .003 ANGLES: ± 1/2° | | <table border="1"> <thead> <tr> <th>APPROVALS</th> <th>DATE</th> </tr> </thead> <tbody> <tr> <td>DRAWN B. KNOTT</td> <td>7/24/2014</td> </tr> <tr> <td>CHECKED JEM</td> <td>7/24/2014</td> </tr> <tr> <td>QA</td> <td></td> </tr> <tr> <td>MFG</td> <td></td> </tr> <tr> <td>ENGINEER B. KNOTT</td> <td>7/24/2014</td> </tr> <tr> <td>APPROVED JEM</td> <td>7/24/2014</td> </tr> </tbody> </table> | | APPROVALS | DATE | DRAWN B. KNOTT | 7/24/2014 | CHECKED JEM | 7/24/2014 | QA | | MFG | | ENGINEER B. KNOTT | 7/24/2014 | APPROVED JEM | 7/24/2014 | TITLE ADAPTER, PkZ® RECEPTACLE TO 2.92mm RECEPTACLE | | | | | | | | | | | | | | | |
| APPROVALS | DATE | | | | | | | | | | | | | | | | | | | | | | | | | | | | | | | | | | | | | | |
| DRAWN B. KNOTT | 7/24/2014 | | | | | | | | | | | | | | | | | | | | | | | | | | | | | | | | | | | | | | |
| CHECKED JEM | 7/24/2014 | | | | | | | | | | | | | | | | | | | | | | | | | | | | | | | | | | | | | | |
| QA | | | | | | | | | | | | | | | | | | | | | | | | | | | | | | | | | | | | | | | |
| MFG | | | | | | | | | | | | | | | | | | | | | | | | | | | | | | | | | | | | | | | |
| ENGINEER B. KNOTT | 7/24/2014 | | | | | | | | | | | | | | | | | | | | | | | | | | | | | | | | | | | | | | |
| APPROVED JEM | 7/24/2014 | | | | | | | | | | | | | | | | | | | | | | | | | | | | | | | | | | | | | | |
| <table border="1"> <thead> <tr> <th>REV.</th> <th>DESCRIPTION</th> <th>DATE</th> <th>BY</th> </tr> </thead> <tbody> <tr> <td>F</td> <td>PER ECN 12720</td> <td>12/1/17</td> <td>SPS</td> </tr> <tr> <td>E</td> <td>PER ECN 12520</td> <td>5/25/17</td> <td>RMB</td> </tr> <tr> <td>D</td> <td>PER ECN 12381</td> <td>10/25/16</td> <td>RMB</td> </tr> <tr> <td>C</td> <td>PER ECN 12302</td> <td>4/26/16</td> <td>RMB</td> </tr> <tr> <td>B</td> <td>PER ECN 12139</td> <td>4/2/15</td> <td>JEM</td> </tr> <tr> <td>A</td> <td>ECN 11940</td> <td>8/1/14</td> <td>JEM</td> </tr> </tbody> </table> | | REV. | DESCRIPTION | DATE | BY | F | PER ECN 12720 | 12/1/17 | SPS | E | PER ECN 12520 | 5/25/17 | RMB | D | PER ECN 12381 | 10/25/16 | RMB | C | PER ECN 12302 | 4/26/16 | RMB | B | PER ECN 12139 | 4/2/15 | JEM | A | ECN 11940 | 8/1/14 | JEM | SIZE B | | FSCM 58167 | | DWG NO 1562_9-1100-00 | | REV F | | PLATING OPT. G, P | |
| REV. | DESCRIPTION | DATE | BY | | | | | | | | | | | | | | | | | | | | | | | | | | | | | | | | | | | | |
| F | PER ECN 12720 | 12/1/17 | SPS | | | | | | | | | | | | | | | | | | | | | | | | | | | | | | | | | | | | |
| E | PER ECN 12520 | 5/25/17 | RMB | | | | | | | | | | | | | | | | | | | | | | | | | | | | | | | | | | | | |
| D | PER ECN 12381 | 10/25/16 | RMB | | | | | | | | | | | | | | | | | | | | | | | | | | | | | | | | | | | | |
| C | PER ECN 12302 | 4/26/16 | RMB | | | | | | | | | | | | | | | | | | | | | | | | | | | | | | | | | | | | |
| B | PER ECN 12139 | 4/2/15 | JEM | | | | | | | | | | | | | | | | | | | | | | | | | | | | | | | | | | | | |
| A | ECN 11940 | 8/1/14 | JEM | | | | | | | | | | | | | | | | | | | | | | | | | | | | | | | | | | | | |
| | | SCALE 4: 1 | | F.S.R. # | | SHEET 1 OF 1 | | | | | | | | | | | | | | | | | | | | | | | | | | | | | | | | | |