

NOTES:

1. SPECIFICATIONS PER IDS-168L.
2. SOLDER NUT SHIPPED LOOSE.
3. ACCOMMODATES RG-405 (.086 SEMI-RIGID) OR EQUIVALENT FLEXIBLE CABLE.
4. FREQUENCY: DC TO 18 GHz.
5. HOUSING: ARINC 600 CONNECTOR PER MIL-C-83527/4, SIZE 12 CAVITY.
6. **DOES NOT MATE WITH OTHER INDUSTRY-STANDARD SIZE 12 CONTACTS.**

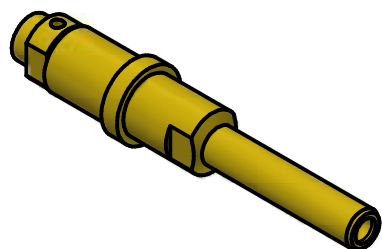

SCALE 2.5 : 1

A	PER ECN 14383	4/9/2024	SPS
REV	DESCRIPTION	DATE	BY

THE INFORMATION AND DESIGNS DISCLOSED IN THIS DOCUMENT ARE CONFIDENTIAL AND/OR PROPRIETARY TO THE PHOENIX COMPANY OF CHICAGO INC. AND MAY NOT BE USED FOR MANUFACTURING, REPRODUCED, DISCLOSED TO OTHERS OR FOR ANY OTHER PURPOSE WITHOUT THE EXPRESS WRITTEN CONSENT OF THE PHOENIX COMPANY OF CHICAGO INC.

WARNING - THIS DOCUMENT CONTAINS TECHNICAL DATA WHOSE EXPORT IS RESTRICTED BY THE ARMS EXPORT CONTROL ACT (TITLE 22, U.S.C., SEC 2751, ET. SEQ.) OR THE EXPORT ADMINISTRATION ACT OF 1979, AS AMENDED, TITLE 50, U.S.C., APP 2401 ET SEQ. VIOLATIONS OF THESE EXPORT LAWS ARE SUBJECT TO SEVERE CRIMINAL PENALTIES. DISSEMINATE IN ACCORDANCE WITH PROVISIONS OF DOD DIRECTIVE 5230.25.

Filename: \\Autodesk Inventor Data Base\Assemblies\78 Series\78-1080-0670-CU-Layout for C Sized Drawing.idw		
UNLESS OTHERWISE SPECIFIED, PHOENIX WORKMANSHIP STANDARDS APPLY DIMENSIONS IN INCHES OR (METRIC) DO NOT SCALE PRINTS TOLERANCES ARE: FRACTIONS: ± 1/64 DECIMALS: .XX ± .01 .XXX ± .003 ANGLES: ± 1/2°	APPROVALS	DATE
	DRAWN RA	4/8/2024
	CHECKED SPS	4/8/2024
	QA	
	MFG	
	ENGINEER SPS	4/8/2024
APPROVED SPS	4/8/2024	

The PHOENIX Company of Chicago, Inc.			
22 GREAT HILL RD., NAUGATUCK, CT 06770 WWW.PHOENIXOFCHICAGO.COM PHONE: (800) 323-9562 FAX:(630) 206-1801			
TITLE PKZ® PLUG, SOLDER/CLAMP TERMINATION			
SIZE B	FSCM 58167	DWG NO 168L-0030-0860	REV A
SCALE		F.S.R. #	PLATING OPT. A, C
SHEET 1		OF 1	