

4

3

2

1

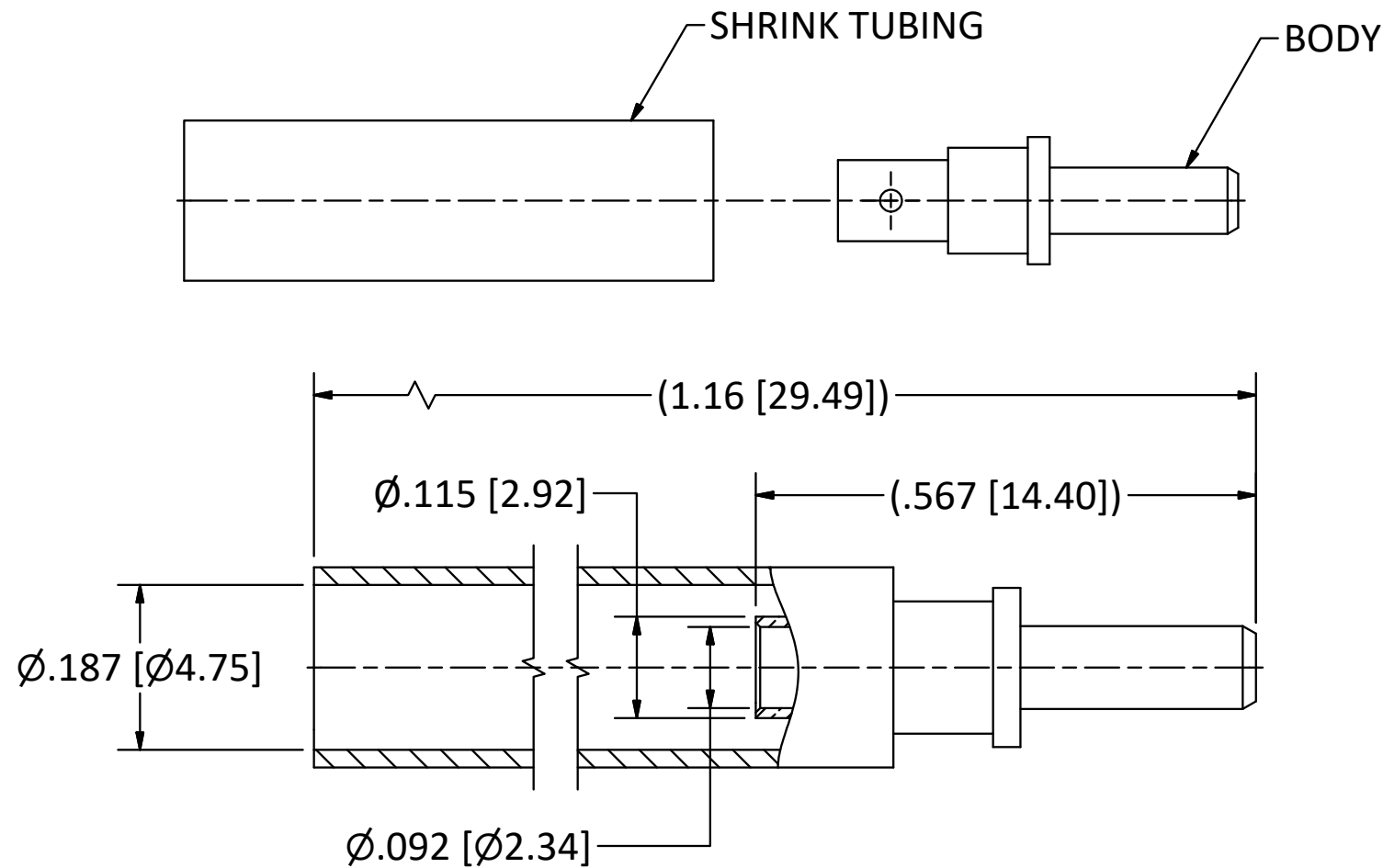

NOTES:

- 1. SPECIFICATIONS PER IDS-178.
- 2. SHRINK TUBING SUPPLIED LOOSE.
- 3. ACCOMMODATES RG-405 (.086 SEMI-RIGID) OR EQUIVALENT FLEXIBLE CABLE.
- 4. ELECTRICAL RESULTS WHEN MATED TO 178 SERIES SIZE 12 PkZ® RECEPTACLE:
 - a) FREQUENCY: DC TO 50 GHz.
 - b) VSWR: 1.40:1 (MAX) UP TO 40 GHz.

HOUSING: MIL-C-38999 SERIES I-IV AND MIGHTY MOUSE SERIES 80, SIZE 12 CAVITY.

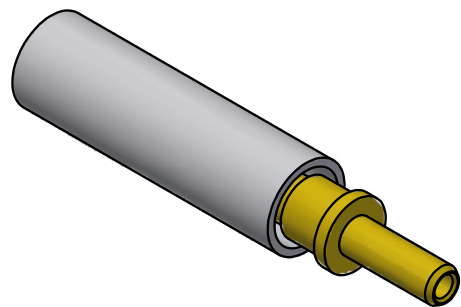

SCALE 2.5 : 1

REV	DESCRIPTION	DATE	BY
H	PER ECN 13684	10/31/2022	SPS
G	PER ECN 13292	4/22/19	JEM
F	PER ECN 13167	10/26/18	JEM
E	PER ECN 13103	9/14/18	JEM
D	PER ECN 13022	6/29/18	JEM
C	PER ECN 12972	6/4/18	JEM
B	PER ECN 12708	11/21/17	JEM
A	PER ECN 12662	10/10/17	RMB

This drawing embodies a proprietary design of The Phoenix Company of Chicago, Inc., Naugatuck, CT 06770. All design, manufacturing, reproduction, use, sale, and other rights regarding the same are expressly reserved. The information in this drawing may be covered completely or in part by patents and/or patents pending.

WARNING - THIS DOCUMENT CONTAINS TECHNICAL DATA WHOSE EXPORT IS RESTRICTED BY THE ARMS EXPORT CONTROL ACT (TITLE 22, U.S.C., SEC 2751, ET. SEQ.) OR THE EXPORT ADMINISTRATION ACT OF 1979, AS AMENDED, TITLE 50, U.S.C., APP 2401 ET SEQ. VIOLATIONS OF THESE EXPORT LAWS ARE SUBJECT TO SEVERE CRIMINAL PENALTIES. DISSEMINATE IN ACCORDANCE WITH PROVISIONS OF DOD DIRECTIVE 5230.25.

Filename: ver2\Autodesk Inventor Data Base\Assemblies\178 Series\178-0021-0863-CU.idw

UNLESS OTHERWISE SPECIFIED, PHOENIX WORKMANSHIP STANDARDS APPLY DIMENSIONS IN INCHES OR (METRIC)

DO NOT SCALE PRINTS

TOLERANCES ARE:
FRACTIONS: ± 1/64
DECIMALS: .XX ± .01
.XXX ± .003
ANGLES: ± 1/2°

32√

APPROVALS	DATE
DRAWN JEM	10/11/2017
CHECKED SPS	10/31/2022
QA	
MFG	
ENGINEER JEM	10/11/2017
APPROVED SPS	10/31/2022

The PHOENIX Company of Chicago, Inc.

22 GREAT HILL RD., NAUGATUCK, CT 06770
WWW.PHOENIXOFCHICAGO.COM
PHONE: (800) 323-9562 FAX:(630) 206-1801

TITLE
PkZ® PLUG, SIZE 12, DIRECT SOLDER, FOR 38999 HOUSING

SIZE	FSCM	DWG NO	REV	PLATING OPT.
B	58167	178-0021-0863	H	A, C
SCALE	5 : 1	F.S.R. #	SHEET	1 OF 1

4

3

2

1