

4

3

2

1

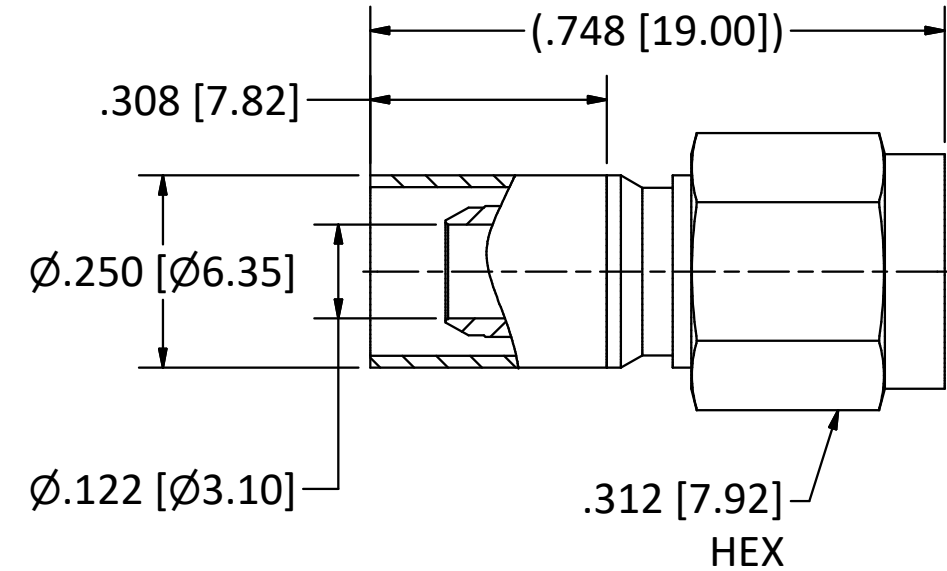
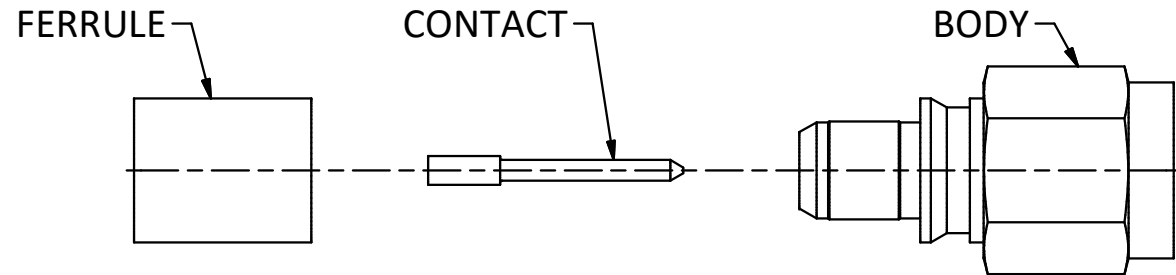

- NOTES:
1. SPECIFICATIONS PER IDS-22J.
  2. CONTACT AND FERRULE SHIPPED LOOSE.
  3. ACCOMMODATES RG-55, RG-142, OR RG-223 CABLE.
  4. CRIMP USING .213 HEX DIE (M22520/5-05).
  5. MAGNETISM: <1.00000 mu.

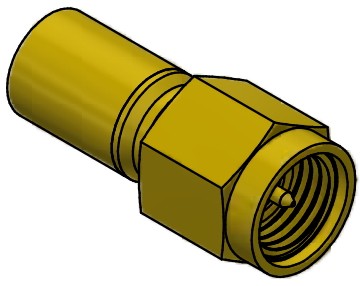

SCALE 2.5 : 1

B	PER ECN 12165	5/13/15	JEM
A	PER ECN 6921	2/27/03	HN
REV.	DESCRIPTION	DATE	BY

This drawing embodies a proprietary design of The Phoenix Company of Chicago, Inc., Naugatuck, CT 06770. All design, manufacturing, reproduction, use, sale, and other rights regarding the same are expressly reserved. The information in this drawing may be covered completely or in part by patents and/or patents pending.

WARNING - THIS DOCUMENT CONTAINS TECHNICAL DATA WHOSE EXPORT IS RESTRICTED BY THE ARMS EXPORT CONTROL ACT (TITLE 22, U.S.C., SEC 2751, ET. SEQ.) OR THE EXPORT ADMINISTRATION ACT OF 1979, AS AMENDED, TITLE 50, U.S.C., APP 2401 ET SEQ. VIOLATIONS OF THESE EXPORT LAWS ARE SUBJECT TO SEVERE CRIMINAL PENALTIES. DISSEMINATE IN ACCORDANCE WITH PROVISIONS OF DOD DIRECTIVE 5230.25.

Filename: ver2\Autodesk Inventor Data Base\Assemblies\2X Series\22-0800-1201J-CU.idw		
UNLESS OTHERWISE SPECIFIED, PHOENIX WORKMANSHIP STANDARDS APPLY DIMENSIONS IN INCHES OR (METRIC)  DO NOT SCALE PRINTS  TOLERANCES ARE: FRACTIONS: ± 1/64 DECIMALS: .XX ± .01 .XXX ± .003 ANGLES: ± 1/2°	APPROVALS	DATE
	DRAWN YT	2/27/2003
	CHECKED HN	2/27/2003
	QA	
	MFG	
ENGINEER YT	2/27/2003	
APPROVED HN	2/27/2003	

<b>The PHOENIX Company of Chicago, Inc.</b>					
22 GREAT HILL RD., NAUGATUCK, CT 06770 WWW.PHOENIXOFCHICAGO.COM PHONE: (800) 323-9562 FAX:(630) 206-1801					
TITLE <b>SMA PLUG, CRIMP/CLAMP TERMINATION</b>					
SIZE B	FSCM 58167	DWG NO <b>22-0800-1201J</b>	REV B	PLATING OPT.	
SCALE 4 : 1		F.S.R. #	SHEET 1 OF 1		

4

3

2

1