

4

3

2

1

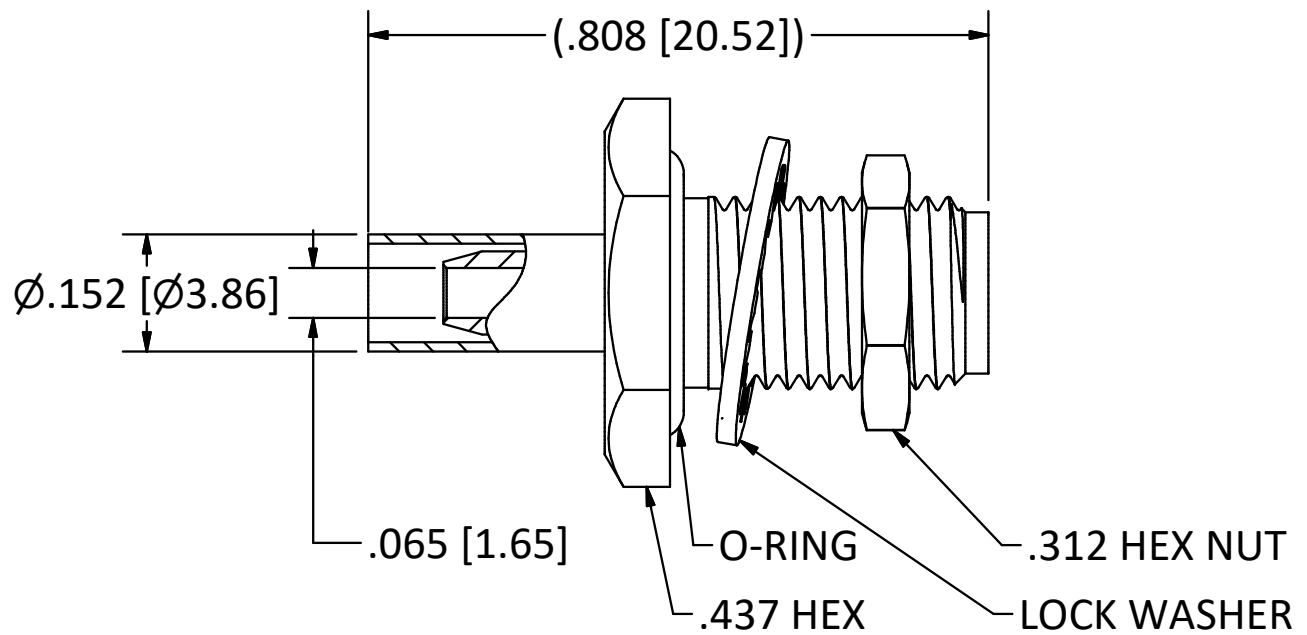
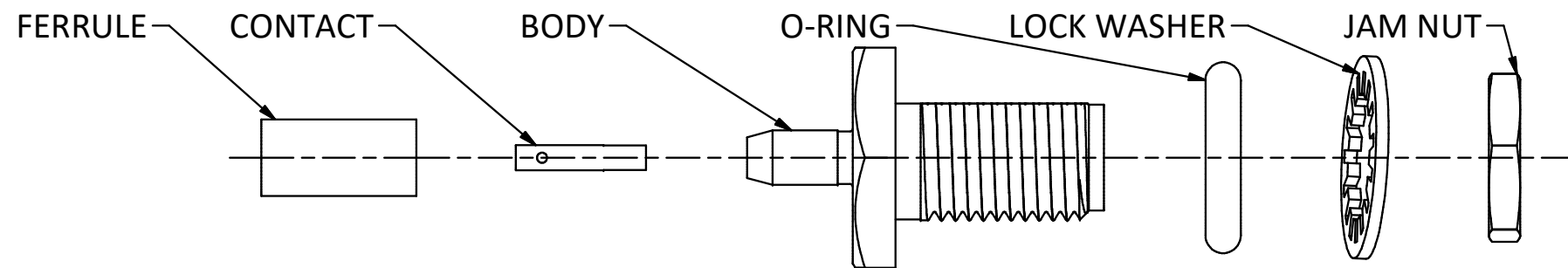

NOTES:

- 1. SPECIFICATIONS PER IDS-22J.
- 2. CONTACT, FERRULE, JAM NUT, LOCK WASHER, AND O-RING SHIPPED LOOSE.
- 3. ACCOMMODATES RG-174, RG-179, RG-187, RG-188, OR RG-316 CABLE.
- 4. MAGNETISM: < 1.00000 mu.

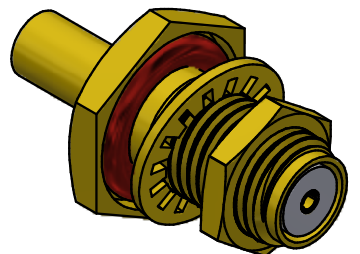

SCALE 2.5 : 1

B	PER ECN 9942	06/04/09	JEM
A	PER ECN 9569	10/14/08	JEM
REV.	DESCRIPTION	DATE	BY

This drawing embodies a proprietary design of The Phoenix Company of Chicago, Inc., Naugatuck, CT 06770. All design, manufacturing, reproduction, use, sale, and other rights regarding the same are expressly reserved. The information in this drawing may be covered completely or in part by patents and/or patents pending.

WARNING - THIS DOCUMENT CONTAINS TECHNICAL DATA WHOSE EXPORT IS RESTRICTED BY THE ARMS EXPORT CONTROL ACT (TITLE 22, U.S.C., SEC 2751, ET. SEQ.) OR THE EXPORT ADMINISTRATION ACT OF 1979, AS AMENDED, TITLE 50, U.S.C., APP 2401 ET SEQ. VIOLATIONS OF THESE EXPORT LAWS ARE SUBJECT TO SEVERE CRIMINAL PENALTIES. DISSEMINATE IN ACCORDANCE WITH PROVISIONS OF DOD DIRECTIVE 5230.25.

Filename: ver2\Autodesk Inventor Data Base\Assemblies\2X Series\22-1865-0670J-CU.idw		
UNLESS OTHERWISE SPECIFIED, PHOENIX WORKMANSHIP STANDARDS APPLY DIMENSIONS IN INCHES OR (METRIC)	APPROVALS	DATE
	DRAWN YT	10/14/2008
DO NOT SCALE PRINTS	CHECKED HN	10/14/2008
	QA	
TOLERANCES ARE: FRACTIONS: ± 1/64 DECIMALS: .XX ± .01 .XXX ± .003 ANGLES: ± 1/2°	MFG	
	ENGINEER YT	10/14/2008
	APPROVED HN	10/14/2008

The PHOENIX Company of Chicago, Inc.				
22 GREAT HILL RD., NAUGATUCK, CT 06770 WWW.PHOENIXOFCHICAGO.COM PHONE: (800) 323-9562 FAX:(630) 206-1801				
TITLE SMA JACK, STRAIGHT, BULKHEAD, CRIMP TYPE				
SIZE B	FSCM 58167	DWG NO 22-1865-0670J	REV B	PLATING OPT.
SCALE 4 : 1	F.S.R. #	SHEET 1 OF 1		

4

3

2

1