

4

3

2

1

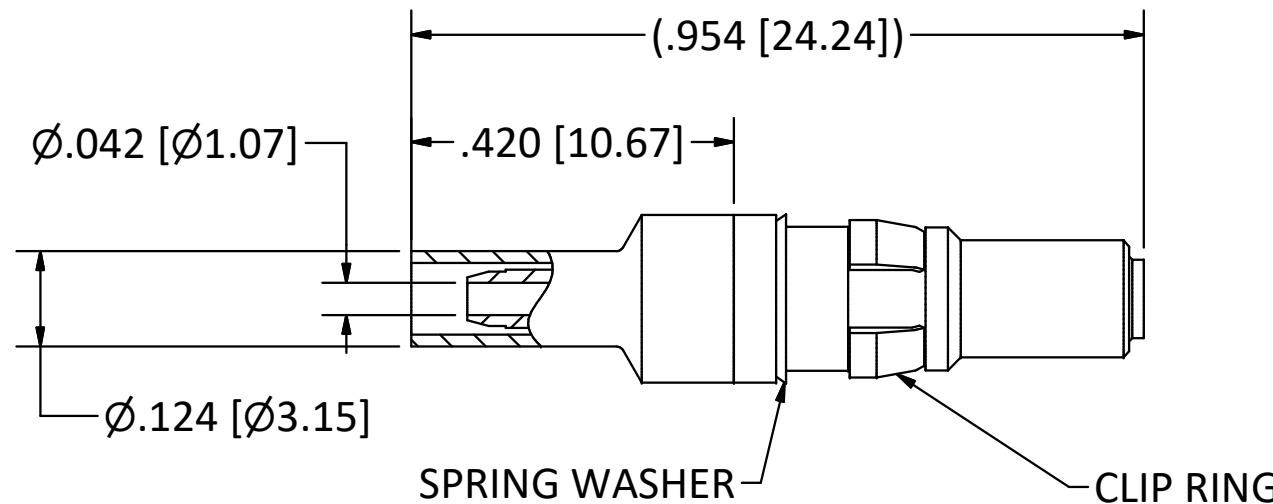
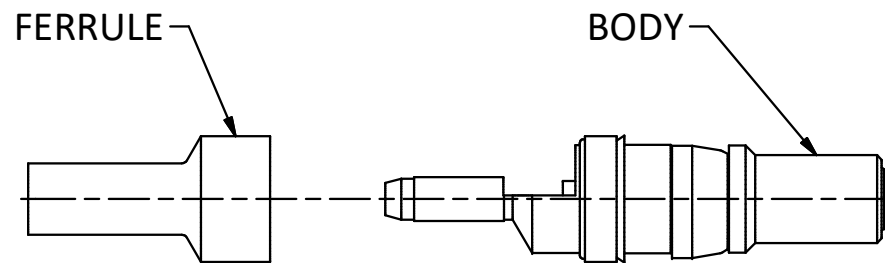

NOTES:

- 1. SPECIFICATIONS PER IDS-24J.
  - 2. FERRULE SHIPPED LOOSE.
  - 3. ACCOMMODATES RG-178 OR RG-196 CABLES.
  - 4. MAGNETISM: <math>< 1.00000 \mu\text{u}</math>.
- HOUSING:** D-SUBMINIATURE, SIZE 8 CAVITY, SHELL SIZE A, B, C, & E.

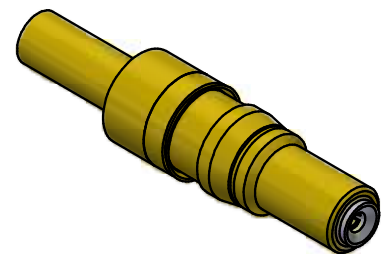

SCALE 2.5 : 1

<p>This drawing embodies a proprietary design of The Phoenix Company of Chicago, Inc., Naugatuck, CT 06770. All design, manufacturing, reproduction, use, sale, and other rights regarding the same are expressly reserved. The information in this drawing may be covered completely or in part by patents and/or patents pending.</p>				<p>WARNING - THIS DOCUMENT CONTAINS TECHNICAL DATA WHOSE EXPORT IS RESTRICTED BY THE ARMS EXPORT CONTROL ACT (TITLE 22, U.S.C., SEC 2751, ET. SEQ.) OR THE EXPORT ADMINISTRATION ACT OF 1979, AS AMENDED, TITLE 50, U.S.C., APP 2401 ET SEQ. VIOLATIONS OF THESE EXPORT LAWS ARE SUBJECT TO SEVERE CRIMINAL PENALTIES. DISSEMINATE IN ACCORDANCE WITH PROVISIONS OF DOD DIRECTIVE 5230.25.</p>		<p>Filename: ver2\Autodesk Inventor Data Base\Assemblies\24 Series\24-0080-0400J-CU.idw</p>		<p><b>The PHOENIX Company of Chicago, Inc.</b>          22 GREAT HILL RD., NAUGATUCK, CT 06770          WWW.PHOENIXOFCHICAGO.COM          PHONE: (800) 323-9562 FAX:(630) 206-1801</p>											
						<p>UNLESS OTHERWISE SPECIFIED, PHOENIX WORKMANSHIP STANDARDS APPLY DIMENSIONS IN INCHES OR (METRIC)</p> <p>DO NOT SCALE PRINTS</p> <p>TOLERANCES ARE:          FRACTIONS: <math>\pm 1/64</math>          DECIMALS: <math>.XX \pm .01</math>  <math>.XXX \pm .003</math>          ANGLES: <math>\pm 1/2^\circ</math></p>				<table border="1"> <thead> <tr> <th>APPROVALS</th> <th>DATE</th> </tr> </thead> <tbody> <tr> <td>DRAWN YT</td> <td>8/8/2006</td> </tr> <tr> <td>CHECKED JM</td> <td>8/8/2006</td> </tr> <tr> <td>QA</td> <td></td> </tr> <tr> <td>MFG</td> <td></td> </tr> <tr> <td>ENGINEER YT</td> <td>8/8/2006</td> </tr> <tr> <td>APPROVED JM</td> <td>8/8/2006</td> </tr> </tbody> </table>		APPROVALS	DATE	DRAWN YT	8/8/2006	CHECKED JM	8/8/2006	QA	
APPROVALS	DATE																		
DRAWN YT	8/8/2006																		
CHECKED JM	8/8/2006																		
QA																			
MFG																			
ENGINEER YT	8/8/2006																		
APPROVED JM	8/8/2006																		
<table border="1"> <thead> <tr> <th>REV.</th> <th>DESCRIPTION</th> <th>DATE</th> <th>BY</th> </tr> </thead> <tbody> <tr> <td>G</td> <td>PER ECN 8605</td> <td>08/08/06</td> <td>JM</td> </tr> </tbody> </table>		REV.	DESCRIPTION	DATE	BY	G	PER ECN 8605	08/08/06	JM	<p>SIZE <b>B</b></p>	<p>FSCM 58167</p>	<p>DWG NO <b>24-0080-0400J</b></p>	<p>REV <b>G</b></p>	<p>PLATING OPT.</p>					
REV.	DESCRIPTION	DATE	BY																
G	PER ECN 8605	08/08/06	JM																
<p>SCALE 4 : 1</p>		<p>F.S.R. #</p>		<p>SHEET 1 OF 1</p>															

4

3

2

1