

CABLE ASSEMBLY PROCEDURE		PALEO CONNECTOR 22 GREAT HILL ROAD, NAUGATUCK, CT. 06770 PHONE: (203) 729-9090 FAX: (203) 723-1794	REV	DESCRIPTION	DATE	APPR
P/N 26-002X-0860			F	PER ECN 9912	05/06/09	JEM
PAGE 1 OF 2	DATE: 03/20/96		G	PER ECN 10224	03/09/10	JEM
DRAWN: EK	APPROVED: JEM		H	PER ECN 10442	06/30/10	JEM
FOR USE WITH RG-405 CABLE		K	PER ECN 10538	08/18/10	JEM	

FOR USE WITH RG-405

STEP 1

TRIM CABLE TO DIMENSIONS SHOWN.
POINT END AS SHOWN.

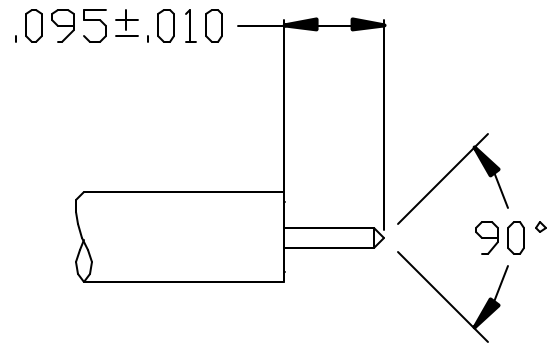

STEP 2

INSERT CABLE INTO BODY AND SOLDER AS SHOWN. CLEAN SOLDER JOINT.

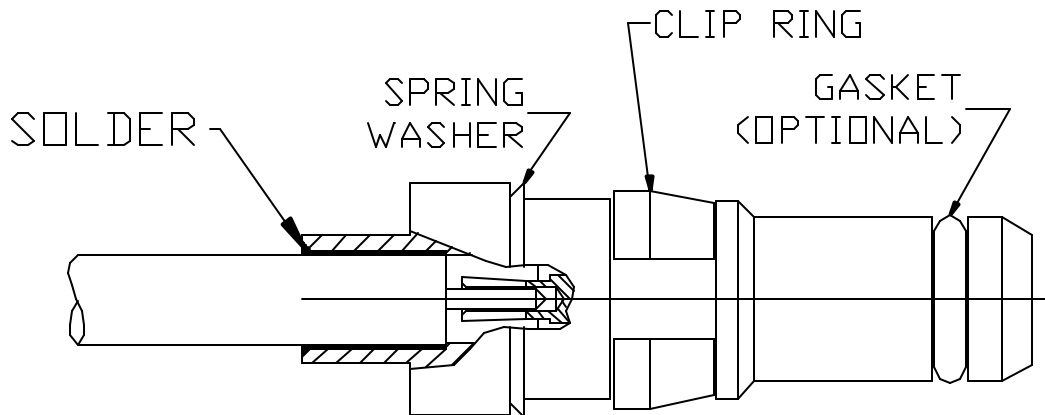

CABLE ASSEMBLY PROCEDURE	
P/N	26-002X-0860
PAGE 2 OF 2	DATE: 03/20/96
DRAWN: EK	APPROVED: JEM
FOR USE WITH TFLEX-405 CABLE	

PALEO
CONNECTOR

22 GREAT HILL ROAD, NAUGATUCK, CT. 06770
PHONE: (203) 729-9090 FAX: (203) 723-1794

REV	DESCRIPTION	DATE	APPR
F	PER ECN 9912	05/06/09	JEM
G	PER ECN 10224	03/09/10	JEM
H	PER ECN 10442	06/30/10	JEM
K	PER ECN 10538	08/18/10	JEM

FOR USE WITH TFLEX-405

STEP 1
TIN DIP CABLE TO
DIMENSIONS SHOWN.

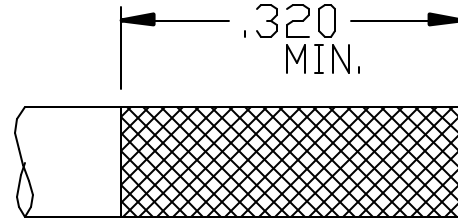

STEP 2
TRIM CABLE TO DIMENSIONS
SHOWN AND POINT
CENTER CONDUCTOR.

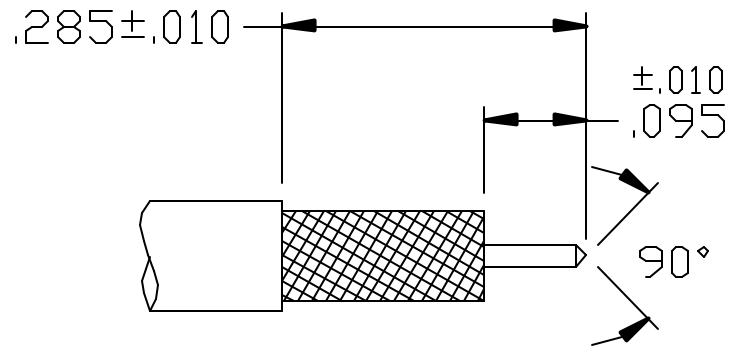

STEP 3
INSERT CABLE INTO BODY AND SOLDER
AS SHOWN. CLEAN SOLDER JOINT.

