

4 | 3 | 2 | 1

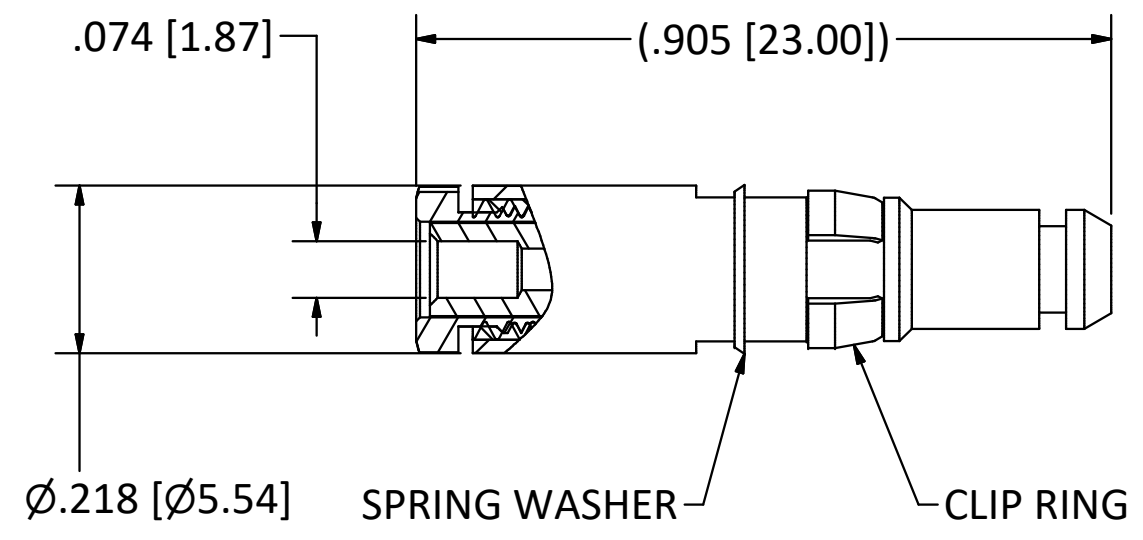

- NOTES:**
1. SPECIFICATIONS PER IDS-26J.
  2. BULLET, CLAMP NUT, SOLDER FERRULE, AND SPACER SHIPPED LOOSE.
  3. ACCOMMODATES RG-178, RG-196, OR 1.37mm CABLE.
  4. MAGNETISM: <1.00000 mu.

PART NUMBER	O-RING OPTIONS
26-XXX0-XXXX	NONE
26-XXX1-XXXX	ENVIRONMENTAL
26-XXX3-XXXX	EMI SPRING
26-XXX5-XXXX	GROUNDING RING

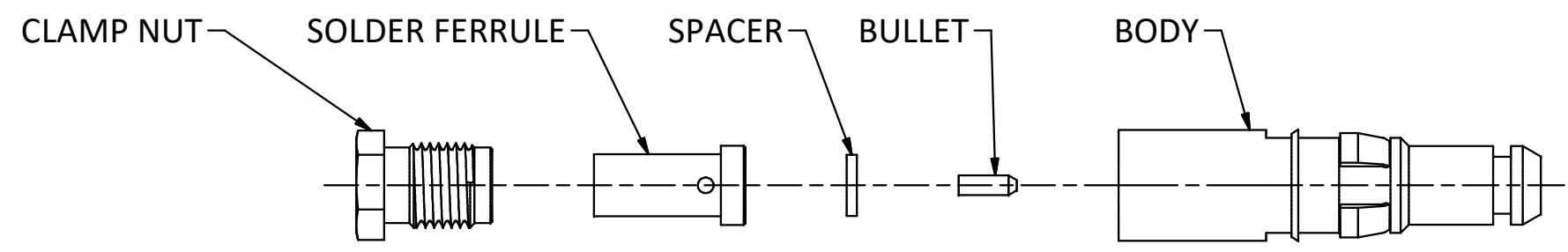
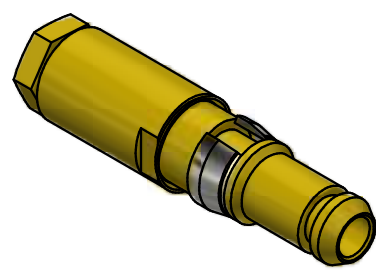

SCALE 2.5 : 1

C	PER ECN 12940	05/02/18	JEM
REV	DESCRIPTION	DATE	BY

This drawing embodies a proprietary design of The Phoenix Company of Chicago, Inc., Naugatuck, CT 06770. All design, manufacturing, reproduction, use, sale, and other rights regarding the same are expressly reserved. The information in this drawing may be covered completely or in part by patents and/or patents pending.

WARNING - THIS DOCUMENT CONTAINS TECHNICAL DATA WHOSE EXPORT IS RESTRICTED BY THE ARMS EXPORT CONTROL ACT (TITLE 22, U.S.C., SEC 2751, ET. SEQ.) OR THE EXPORT ADMINISTRATION ACT OF 1979, AS AMENDED, TITLE 50, U.S.C., APP 2401 ET SEQ. VIOLATIONS OF THESE EXPORT LAWS ARE SUBJECT TO SEVERE CRIMINAL PENALTIES. DISSEMINATE IN ACCORDANCE WITH PROVISIONS OF DOD DIRECTIVE 5230.25.

Filename: ver2\Autodesk Inventor Data Base\Assemblies\26 Series\26-0030-0400J-CU.idw

UNLESS OTHERWISE SPECIFIED, PHOENIX WORKMANSHIP STANDARDS APPLY DIMENSIONS IN INCHES OR (METRIC)	APPROVALS	DATE
DO NOT SCALE PRINTS	DRAWN	TSS 5/2/2018
	CHECKED	JEM 5/2/2018
TOLERANCES ARE: FRACTIONS: ± 1/64 DECIMALS: .XX ± .01 .XXX ± .003 ANGLES: ± 1/2°	QA	
	MFG	
	ENGINEER	TSS 5/2/2018
	APPROVED	JEM 5/2/2018

**The PHOENIX Company of Chicago, Inc.**  
 22 GREAT HILL RD., NAUGATUCK, CT 06770  
 WWW.PHOENIXOFCHICAGO.COM  
 PHONE: (800) 323-9562 FAX:(630) 206-1801

TITLE: **PKZ® PLUG, SOLDER/CLAMP TERMINATION**

SIZE	FSCM	DWG NO	REV	PLATING OPT.
B	58167	<b>26-0030-0400J</b>	C	

SCALE 4 : 1 | F.S.R. # | SHEET 1 OF 1

4 | 3 | 2 | 1