

4

3

2

1

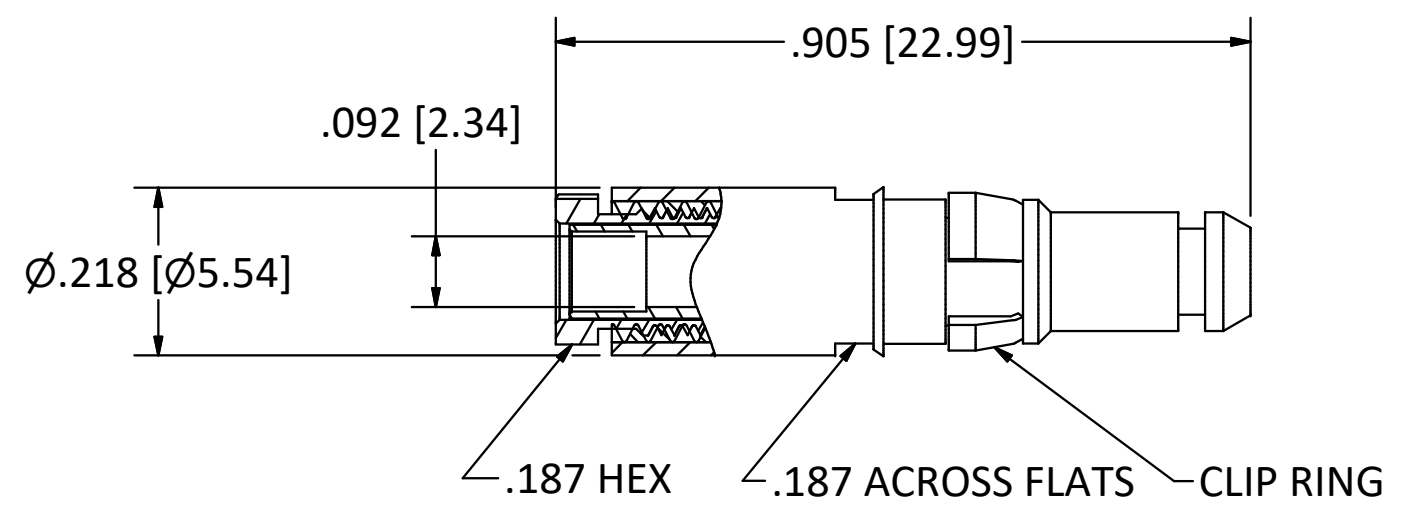
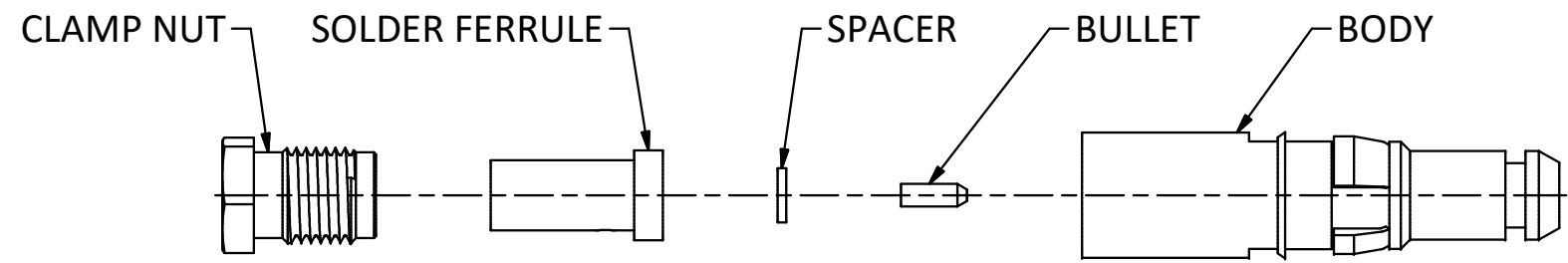

NOTES:

- 1. SPECIFICATIONS PER IDS-26J.
- 2. BULLET, CLAMP NUT, SOLDER FERRULE, AND SPACER SHIPPED LOOSE.
- 3. ACCOMMODATES RG-174, RG-179, RG-187, RG-188, OR RG-316 CABLE.
- 4. MAGNETISM: <1.00000mu.

PART NUMBER	O-RING OPTIONS
26-XXX0-XXXX	NONE
26-XXX1-XXXX	ENVIRONMENTAL
26-XXX3-XXXX	EMI SPRING
26-XXX5-XXXX	GROUNDING RING

**The PHOENIX Company of Chicago, Inc.**  
 22 GREAT HILL RD., NAUGATUCK, CT 06770  
 WWW.PHOENIXOFCHICAGO.COM  
 PHONE: (800) 323-9562 FAX:(630) 206-1801

TITLE				PKZ® PLUG, SOLDER/CLAMP TERMINATION	
SIZE	FSCM	DWG NO	REV	PLATING OPT.	
B	58167	<b>26-0030-0670J</b>	L		
SCALE	3 : 1	F.S.R. #	SHEET 1 OF 1		

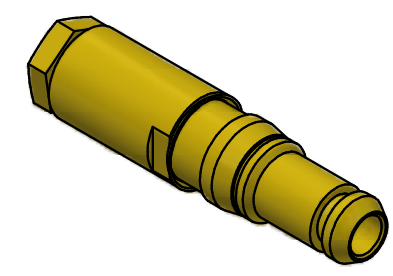

SCALE 2.5 : 1

REV	DESCRIPTION	DATE	BY
R	PER ECN 11004	06/22/09	JEM
P	PER ECN 10689	11/08/10	JEM
N	PER ECN 10297	04/21/10	JEM
M	PER ECN 10109	12/04/09	JEM
L	PER ECN 10025	09/14/09	JEM

This drawing embodies a proprietary design of The Phoenix Company of Chicago, Inc., Naugatuck, CT 06770. All design, manufacturing, reproduction, use, sale, and other rights regarding the same are expressly reserved. The information in this drawing may be covered completely or in part by patents and/or patents pending.

WARNING - THIS DOCUMENT CONTAINS TECHNICAL DATA WHOSE EXPORT IS RESTRICTED BY THE ARMS EXPORT CONTROL ACT (TITLE 22, U.S.C., SEC 2751, ET. SEQ.) OR THE EXPORT ADMINISTRATION ACT OF 1979, AS AMENDED, TITLE 50, U.S.C., APP 2401 ET SEQ. VIOLATIONS OF THESE EXPORT LAWS ARE SUBJECT TO SEVERE CRIMINAL PENALTIES. DISSEMINATE IN ACCORDANCE WITH PROVISIONS OF DOD DIRECTIVE 5230.25.

Filename: ver2\Autodesk Inventor Data Base\Assemblies\26 Series\26-0030-0670J-CU.idw		
UNLESS OTHERWISE SPECIFIED, PHOENIX WORKMANSHIP STANDARDS APPLY DIMENSIONS IN INCHES OR (METRIC)	APPROVALS	DATE
	DRAWN KJT	9/14/2009
DO NOT SCALE PRINTS	CHECKED HN	9/14/2009
	QA	
TOLERANCES ARE: FRACTIONS: ± 1/64 DECIMALS: .XX ± .01 .XXX ± .003 ANGLES: ± 1/2°	MFG	
	ENGINEER YT	9/14/2009
	APPROVED HN	9/14/2009

4

3

2

1