

4

3

2

1

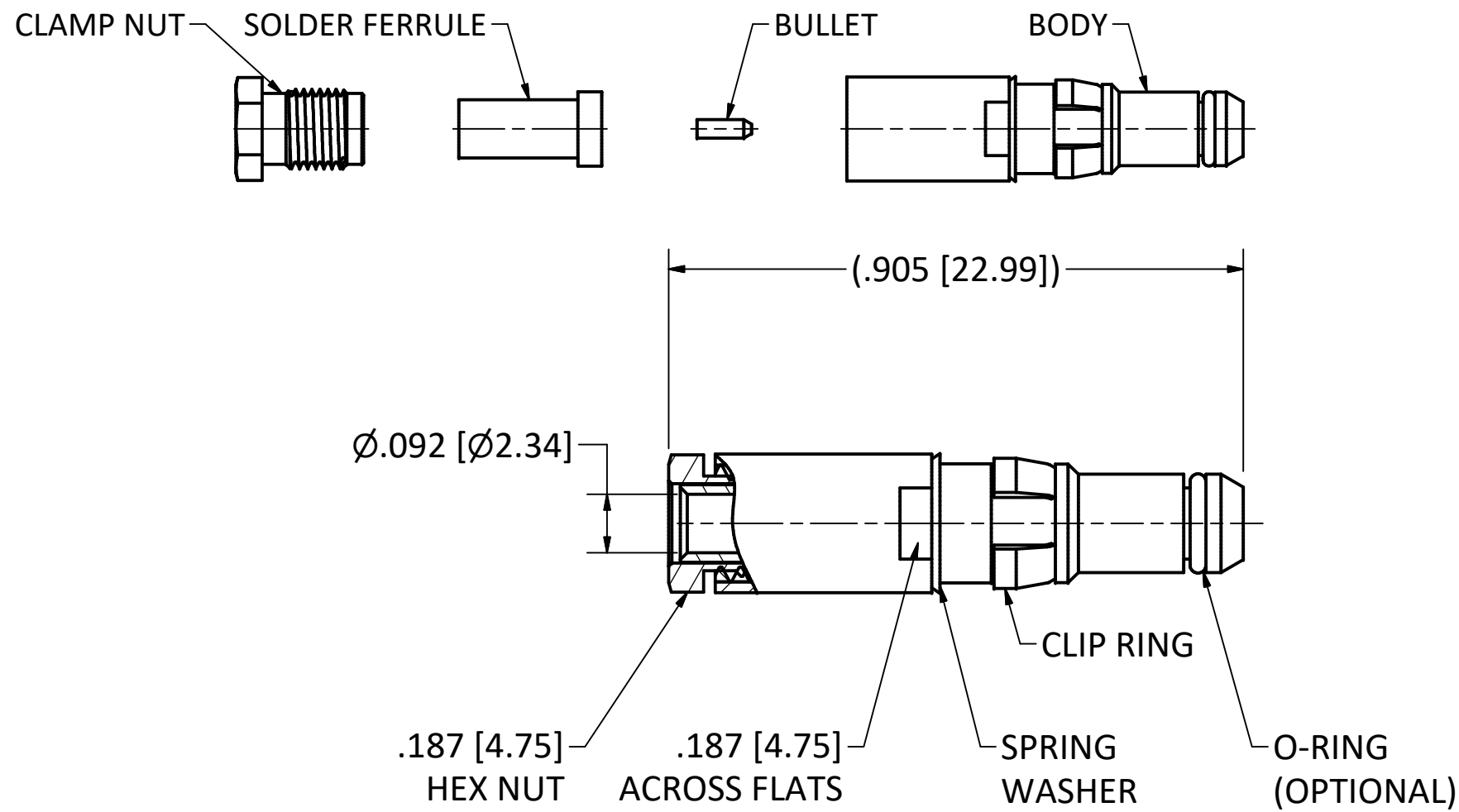

- NOTES:
- SPECIFICATIONS PER IDS-26.
 - CLAMP NUT, SOLDER FERRULE, AND BULLET SHIPPED LOOSE.
 - ACCOMMODATES RG-405 (.086 SEMI-RIGID) OR EQUIVALENT FLEXIBLE CABLE.
- HOUSING:** D-SUBMINIATURE, SIZE 8 CAVITY.

PART NUMBER	O-RING OPTIONS
26-0030-0860	NONE
26-0031-0860	ENVIRONMENTAL
26-0033-0860	EMI SPRING
26-0035-0860	GROUNDING RING

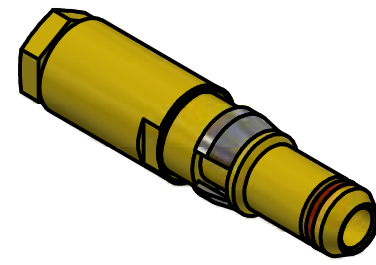

SCALE 2.5 : 1

REV	DESCRIPTION	DATE	BY
S	ECN 110074	6/22/11	JEM
R	ECN 10683	11/5/10	JEM
P	ECN 10187	02/15/10	JEM
O	ECN 10110	12/04/09	JEM
N	ECN 6082	12/03/01	HN

This drawing embodies a proprietary design of The Phoenix Company of Chicago, Inc., Naugatuck, CT 06770. All design, manufacturing, reproduction, use, sale, and other rights regarding the same are expressly reserved. The information in this drawing may be covered completely or in part by patents and/or patents pending.

WARNING - THIS DOCUMENT CONTAINS TECHNICAL DATA WHOSE EXPORT IS RESTRICTED BY THE ARMS EXPORT CONTROL ACT (TITLE 22, U.S.C., SEC 2751, ET. SEQ.) OR THE EXPORT ADMINISTRATION ACT OF 1979, AS AMENDED, TITLE 50, U.S.C., APP 2401 ET SEQ. VIOLATIONS OF THESE EXPORT LAWS ARE SUBJECT TO SEVERE CRIMINAL PENALTIES. DISSEMINATE IN ACCORDANCE WITH PROVISIONS OF DOD DIRECTIVE 5230.25.

Filename: ver2\Autodesk Inventor Data Base\Assemblies\26 Series\26-003X-0860-CU.idw		
UNLESS OTHERWISE SPECIFIED, PHOENIX WORKMANSHIP STANDARDS APPLY DIMENSIONS IN INCHES OR (METRIC) DO NOT SCALE PRINTS TOLERANCES ARE: FRACTIONS: ± 1/64 DECIMALS: .XX ± .01 .XXX ± .003 ANGLES: ± 1/2°	APPROVALS	DATE
	DRAWN MY	3/7/1991
	CHECKED HN	3/7/1991
	QA	
	MFG	
	ENGINEER YT	3/7/1991
APPROVED HN	3/7/1991	

The PHOENIX Company of Chicago, Inc.
 22 GREAT HILL RD., NAUGATUCK, CT 06770
 WWW.PHOENIXOFCHICAGO.COM
 PHONE: (800) 323-9562 FAX:(630) 206-1801

TITLE: **PKZ® PLUG, SOLDER/CLAMP TERMINATION**

SIZE B	FSCM 58167	DWG NO 26-003X-0860	REV S	PLATING OPT. A, B, C, D
SCALE 2.5 : 1		F.S.R. #	SHEET 1 OF 1	

4

3

2

1