

- NOTES:
- SPECIFICATIONS PER IDS-26.
  - CRIMP NUT, CRIMP FERRULE, BULLET AND SPACER SHIPPED LOOSE.
  - ACCOMMODATES RG-178, RG-196, OR 1.37mm CABLE.
  - CRIMP USING .105 HEX DIE (M22520/5-03).
- HOUSING:** D-SUBMINIATURE, SIZE 8 CAVITY.

PART NUMBER	O-RING OPTIONS
26-0080-0400	NONE
26-0081-0400	ENVIRONMENTAL
26-0083-0400	EMI SPRING
26-0085-0400	GROUNDING RING

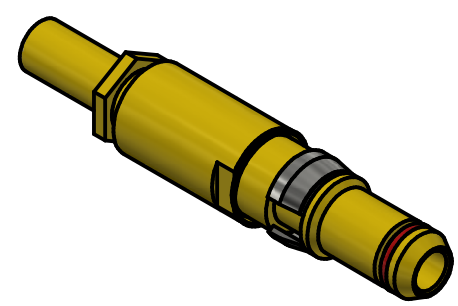

SCALE 2.5 : 1

REV	DESCRIPTION	DATE	BY
A	ECN 9147	11/15/07	JEM

This drawing embodies a proprietary design of The Phoenix Company of Chicago, Inc., Naugatuck, CT 06770. All design, manufacturing, reproduction, use, sale, and other rights regarding the same are expressly reserved. The information in this drawing may be covered completely or in part by patents and/or patents pending.

WARNING - THIS DOCUMENT CONTAINS TECHNICAL DATA WHOSE EXPORT IS RESTRICTED BY THE ARMS EXPORT CONTROL ACT (TITLE 22, U.S.C., SEC 2751, ET. SEQ.) OR THE EXPORT ADMINISTRATION ACT OF 1979, AS AMENDED, TITLE 50, U.S.C., APP 2401 ET SEQ. VIOLATIONS OF THESE EXPORT LAWS ARE SUBJECT TO SEVERE CRIMINAL PENALTIES. DISSEMINATE IN ACCORDANCE WITH PROVISIONS OF DOD DIRECTIVE 5230.25.

Filename: \\Autodesk Inventor Data Base\Assemblies\78 Series\78-1080-0670-CU-Layout for C Sized Drawing.idw		
UNLESS OTHERWISE SPECIFIED, PHOENIX WORKMANSHIP STANDARDS APPLY DIMENSIONS IN INCHES OR (METRIC)  DO NOT SCALE PRINTS  TOLERANCES ARE: FRACTIONS: ± 1/64 DECIMALS: .XX ± .01 .XXX ± .003 ANGLES: ± 1/2°	APPROVALS	DATE
	DRAWN EK	11/15/2007
	CHECKED JEM	11/15/2007
	QA	
	MFG	
	ENGINEER EK	11/15/2007
APPROVED JEM	11/15/2007	

**The PHOENIX Company of Chicago, Inc.**  
 22 GREAT HILL RD., NAUGATUCK, CT 06770  
 WWW.PHOENIXOFCHICAGO.COM  
 PHONE: (800) 323-9562 FAX:(630) 206-1801

TITLE  
**PKZ® PLUG, SOLDER/CRIMP TERMINATION**

SIZE <b>B</b>	FSCM 58167	DWG NO <b>26-008X-0400</b>	REV A	PLATING OPT. A, B, C, D
SCALE 2.5 : 1		F.S.R. #	SHEET 1 OF 1	