

4 | 3 | 2 | 1

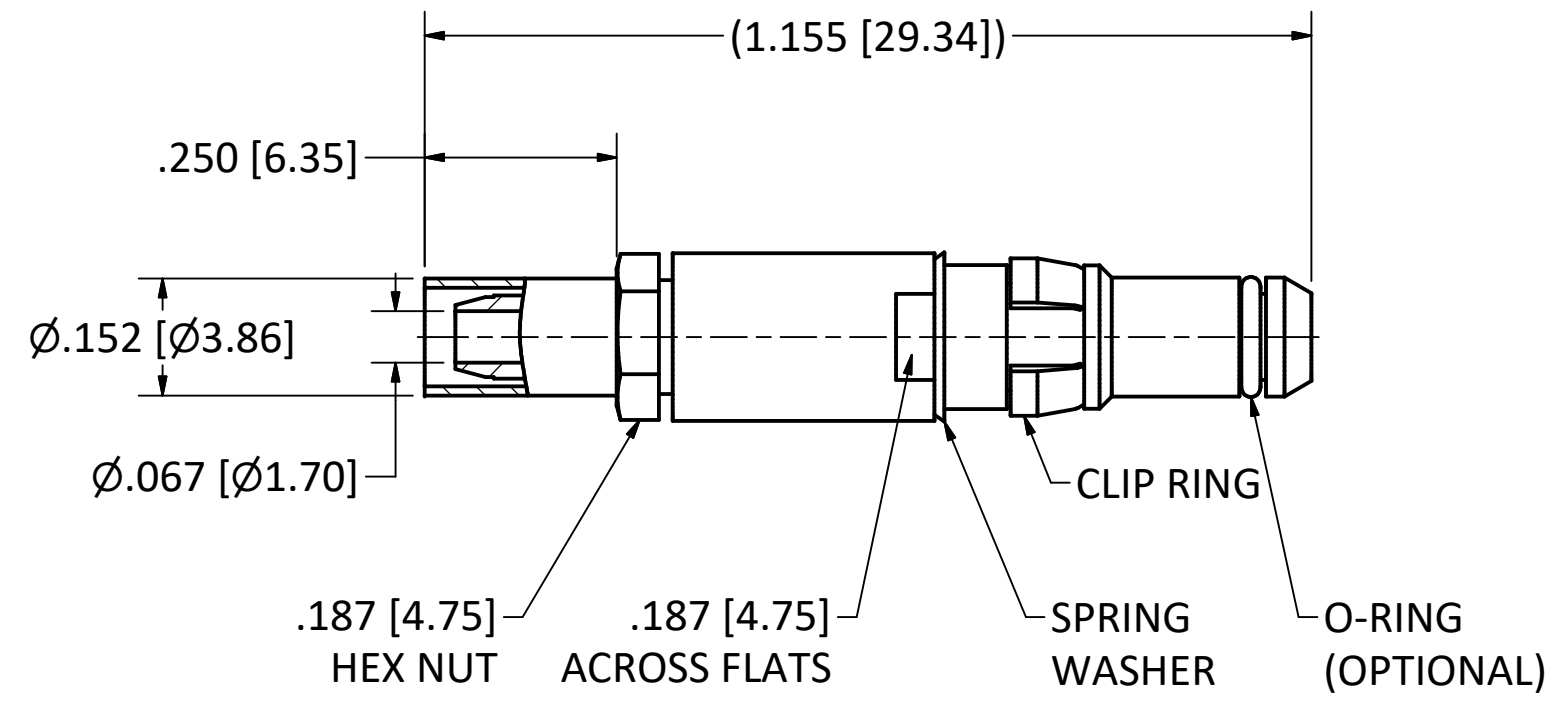

- NOTES:
- SPECIFICATIONS PER IDS-26.
  - BULLET, FERRULE, SPACER, AND CRIMP NUT SHIPPED LOOSE.
  - ACCOMMODATES RG-174, RG-179, RG-187, RG-188, OR RG-316 CABLE.
  - CRIMP USING HEX DIE .128 (M22520/5-03).
- HOUSING:** D-SUBMINIATURE, SIZE 8 CAVITY.

PART NUMBER	O-RING OPTIONS
26-0080-0670	NONE
26-0081-0670	ENVIRONMENTAL
26-0083-0670	EMI SPRING
26-0085-0670	GROUNDING RING

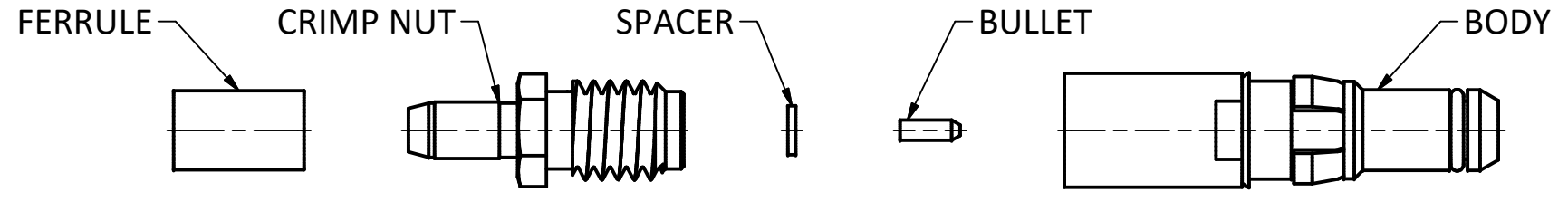
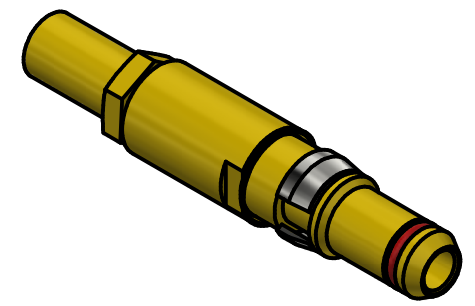

SCALE 2.5 : 1

REV.	DESCRIPTION	DATE	BY
T	PER ECN	9/30/2020	
S	PER ECN 11706	07/09/13	JEM
R	PER ECN 10690	11/08/10	JEM
P	PER ECN 10292	04/20/10	JEM
O	PER ECN 10128	12/15/09	JEM
N	PER ECN 7055	11/19/04	JEM

This drawing embodies a proprietary design of The Phoenix Company of Chicago, Inc., Naugatuck, CT 06770. All design, manufacturing, reproduction, use, sale, and other rights regarding the same are expressly reserved. The information in this drawing may be covered completely or in part by patents and/or patents pending.

WARNING - THIS DOCUMENT CONTAINS TECHNICAL DATA WHOSE EXPORT IS RESTRICTED BY THE ARMS EXPORT CONTROL ACT (TITLE 22, U.S.C., SEC 2751, ET. SEQ.) OR THE EXPORT ADMINISTRATION ACT OF 1979, AS AMENDED, TITLE 50, U.S.C., APP 2401 ET SEQ. VIOLATIONS OF THESE EXPORT LAWS ARE SUBJECT TO SEVERE CRIMINAL PENALTIES. DISSEMINATE IN ACCORDANCE WITH PROVISIONS OF DOD DIRECTIVE 5230.25.

Filename: \\Autodesk Inventor Data Base\Assemblies\78 Series\78-1080-0670-CU-Layout for C Sized Drawing.idw		
UNLESS OTHERWISE SPECIFIED, PHOENIX WORKMANSHIP STANDARDS APPLY DIMENSIONS IN INCHES OR (METRIC)  DO NOT SCALE PRINTS  TOLERANCES ARE: FRACTIONS: ± 1/64 DECIMALS: .XX ± .01 .XXX ± .003 ANGLES: ± 1/2°	APPROVALS	DATE
	DRAWN EK	11/28/1988
	CHECKED JEM	11/28/1988
	QA	
	MFG	
	ENGINEER JSV	11/28/1989
APPROVED HN	11/28/1988	

**The PHOENIX Company of Chicago, Inc.**  
 22 GREAT HILL RD., NAUGATUCK, CT 06770  
 WWW.PHOENIXOFCHICAGO.COM  
 PHONE: (800) 323-9562 FAX:(630) 206-1801

TITLE  
**PkZ® PLUG, CRIMP/CLAMP TERMINATION**

SIZE <b>B</b>	FSCM 58167	DWG NO <b>26-008X-0670</b>	REV T	PLATING OPT. A, B, C, D
SCALE 4 : 1		F.S.R. #	SHEET 1 OF 1	

4 | 3 | 2 | 1