

4 | 3 | 2 | 1

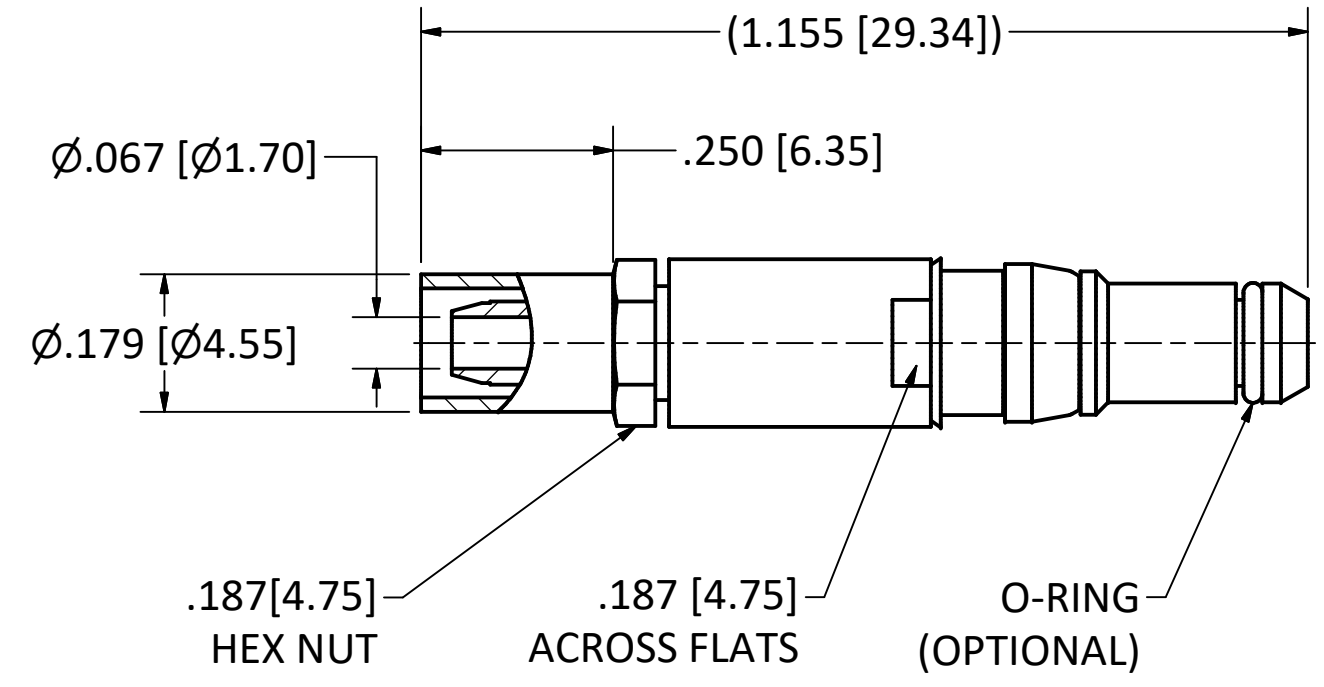
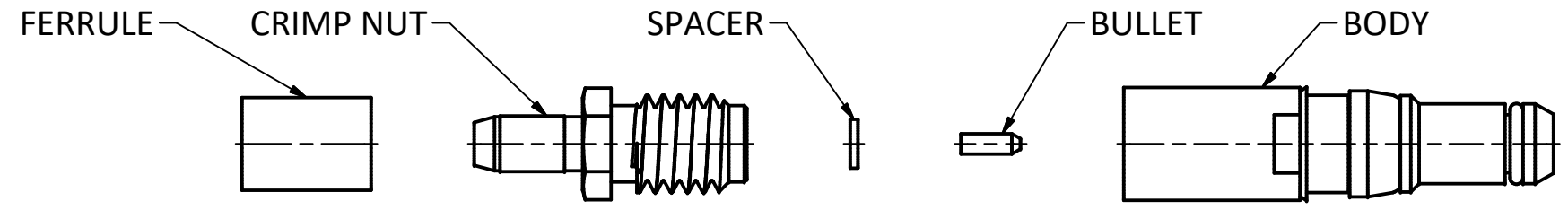

NOTES:

1. SPECIFICATIONS PER IDS-26.
 2. BULLET, CLAMP NUT, FERRULE AND SPACER SHIPPED LOOSE.
 3. ACCOMMODATES RG-316D (M17/152) OR EQUIVALENT CABLES.
 4. CRIMP USING .151 HEX DIE (M22520/5-37).
- HOUSING:** D-SUB, SIZE 8 CAVITY.

| PART NUMBER | O-RING OPTIONS |
|--------------|----------------|
| 26-0080-2670 | NONE |
| 26-0081-2670 | ENVIRONMENTAL |
| 26-0083-2670 | EMI SPRING |
| 26-0085-2670 | GROUNDING RING |

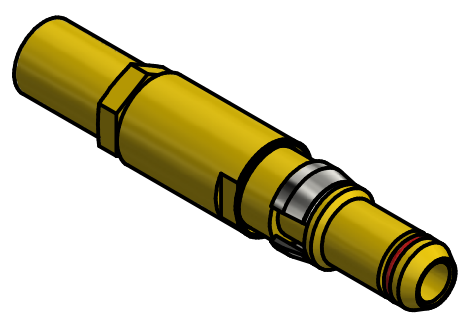

SCALE 2.5 : 1

| REV | DESCRIPTION | DATE | BY |
|-----|-------------|----------|-----|
| F | ECN 10692 | 11/9/10 | JEM |
| E | ECN 10291 | 4/20/10 | JEM |
| D | ECN 10118 | 12/09/09 | JEM |
| C | ECN 5256 | 10/01/99 | HN |
| B | ECN 4185 | 11/21/97 | HN |

THE INFORMATION AND DESIGNS DISCLOSED IN THIS DOCUMENT ARE CONFIDENTIAL AND/OR PROPRIETARY TO THE PHOENIX COMPANY OF CHICAGO INC. AND MAY NOT BE USED FOR MANUFACTURING, REPRODUCED, DISCLOSED TO OTHERS OR FOR ANY OTHER PURPOSE WITHOUT THE EXPRESS WRITTEN CONSENT OF THE PHOENIX COMPANY OF CHICAGO INC.

WARNING - THIS DOCUMENT CONTAINS TECHNICAL DATA WHOSE EXPORT IS RESTRICTED BY THE ARMS EXPORT CONTROL ACT (TITLE 22, U.S.C., SEC 2751, ET. SEQ.) OR THE EXPORT ADMINISTRATION ACT OF 1979, AS AMENDED, TITLE 50, U.S.C., APP 2401 ET SEQ. VIOLATIONS OF THESE EXPORT LAWS ARE SUBJECT TO SEVERE CRIMINAL PENALTIES. DISSEMINATE IN ACCORDANCE WITH PROVISIONS OF DOD DIRECTIVE 5230.25.

| | | |
|--|-----------------|----------|
| Filename: dins\Palco Default Project\26-008X-2670-CU.idw | | |
| UNLESS OTHERWISE SPECIFIED, PHOENIX WORKMANSHIP STANDARDS APPLY DIMENSIONS IN INCHES OR (METRIC) | APPROVALS | DATE |
| | DRAWN CA | 11/10/20 |
| DO NOT SCALE PRINTS | CHECKED JEM | 11/10/20 |
| | QA | |
| TOLERANCES ARE: FRACTIONS: ± 1/64 DECIMALS: .XX ± .01 .XXX ± .003 ANGLES: ± 1/2° | MFG | |
| | ENGINEER JEM | 12/6/94 |
| 32√ | APPROVED HN | 12/6/94 |

The PHOENIX Company of Chicago, Inc.
 22 GREAT HILL RD., NAUGATUCK, CT 06770
 WWW.PHOENIXOFCHICAGO.COM
 PHONE: (800) 323-9562 FAX:(630) 206-1801

TITLE
PkZ® PLUG, CRIMP/CLAMP TERMINATION

| | | | | |
|------------------|---------------|-------------------------------|--------------|-----------------------------|
| SIZE B | FSCM 58167 | DWG NO 26-008X-2670 | REV F | PLATING OPT. A, B, ,C, D |
| SCALE | | F.S.R. # | SHEET 1 OF 1 | |

4 | 3 | 2 | 1