

4

3

2

1

B

B

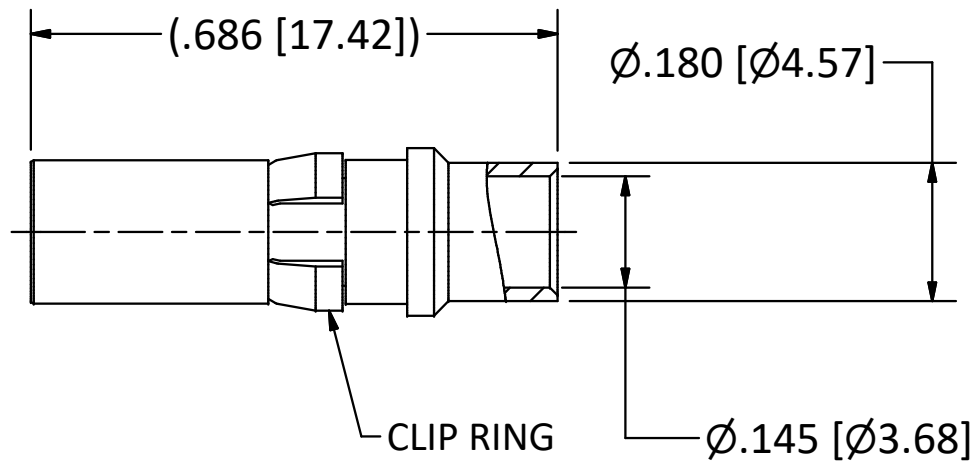

NOTES:
 1. SPECIFICATIONS PER IDS-26.
 2. ACCOMMODATES RG-402 (.141 SEMI-RIGID) OR EQUIVALENT FLEXIBLE CABLE.
HOUSING: D-SUBMINIATURE, SIZE 8 CAVITY.

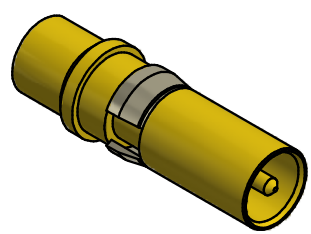

SCALE 2.5 : 1

4

3

2

1

A

A

This drawing embodies a proprietary design of The Phoenix Company of Chicago, Inc., Naugatuck, CT 06770. All design, manufacturing, reproduction, use, sale, and other rights regarding the same are expressly reserved. The information in this drawing may be covered completely or in part by patents and/or patents pending.				WARNING - THIS DOCUMENT CONTAINS TECHNICAL DATA WHOSE EXPORT IS RESTRICTED BY THE ARMS EXPORT CONTROL ACT (TITLE 22, U.S.C., SEC 2751, ET. SEQ.) OR THE EXPORT ADMINISTRATION ACT OF 1979, AS AMENDED, TITLE 50, U.S.C., APP 2401 ET SEQ. VIOLATIONS OF THESE EXPORT LAWS ARE SUBJECT TO SEVERE CRIMINAL PENALTIES. DISSEMINATE IN ACCORDANCE WITH PROVISIONS OF DOD DIRECTIVE 5230.25.		Filename: ver2\Autodesk Inventor Data Base\Assemblies\26 Series\26-1020-1410-CU.idw		The PHOENIX Company of Chicago, Inc. 22 GREAT HILL RD., NAUGATUCK, CT 06770 WWW.PHOENIXOFCHICAGO.COM PHONE: (800) 323-9562 FAX:(630) 206-1801																													
						UNLESS OTHERWISE SPECIFIED, PHOENIX WORKMANSHIP STANDARDS APPLY DIMENSIONS IN INCHES OR (METRIC) DO NOT SCALE PRINTS TOLERANCES ARE: FRACTIONS: ± 1/64 DECIMALS: .XX ± .01 .XXX ± .003 ANGLES: ± 1/2°				<table border="1"> <thead> <tr> <th>APPROVALS</th> <th>DATE</th> </tr> </thead> <tbody> <tr> <td>DRAWN YT</td> <td>6/14/1988</td> </tr> <tr> <td>CHECKED HN</td> <td>6/14/1988</td> </tr> <tr> <td>QA</td> <td></td> </tr> <tr> <td>MFG</td> <td></td> </tr> <tr> <td>ENGINEER YT</td> <td>6/14/1988</td> </tr> <tr> <td>APPROVED HN</td> <td>6/14/1988</td> </tr> </tbody> </table>		APPROVALS	DATE	DRAWN YT	6/14/1988	CHECKED HN	6/14/1988	QA		MFG		ENGINEER YT	6/14/1988	APPROVED HN	6/14/1988	TITLE PkZ® RECEPTACLE, DIRECT SOLDER TERMINATION											
APPROVALS	DATE																																				
DRAWN YT	6/14/1988																																				
CHECKED HN	6/14/1988																																				
QA																																					
MFG																																					
ENGINEER YT	6/14/1988																																				
APPROVED HN	6/14/1988																																				
<table border="1"> <thead> <tr> <th>REV.</th> <th>DESCRIPTION</th> <th>DATE</th> <th>BY</th> </tr> </thead> <tbody> <tr> <td>L</td> <td>ECN 11922</td> <td>07/02/14</td> <td>JEM</td> </tr> <tr> <td>K</td> <td>ECN 10186</td> <td>02/15/10</td> <td>JEM</td> </tr> <tr> <td>J</td> <td>ECN 9759</td> <td>10/21/08</td> <td>JEM</td> </tr> <tr> <td>I</td> <td>ECN 8019</td> <td>06/03/05</td> <td>JM</td> </tr> <tr> <td>H</td> <td>ECN 7224</td> <td>12/16/03</td> <td>HN</td> </tr> </tbody> </table>		REV.	DESCRIPTION	DATE	BY	L	ECN 11922	07/02/14	JEM	K	ECN 10186	02/15/10	JEM	J	ECN 9759	10/21/08	JEM	I	ECN 8019	06/03/05	JM	H	ECN 7224	12/16/03	HN	<table border="1"> <thead> <tr> <th>SIZE</th> <th>FSCM</th> <th>DWG NO</th> <th>REV</th> <th>PLATING OPT.</th> </tr> </thead> <tbody> <tr> <td>B</td> <td>58167</td> <td>26-1020-1410</td> <td>L</td> <td>A, B, C, D</td> </tr> </tbody> </table>		SIZE	FSCM	DWG NO	REV	PLATING OPT.	B	58167	26-1020-1410	L	A, B, C, D
REV.	DESCRIPTION	DATE	BY																																		
L	ECN 11922	07/02/14	JEM																																		
K	ECN 10186	02/15/10	JEM																																		
J	ECN 9759	10/21/08	JEM																																		
I	ECN 8019	06/03/05	JM																																		
H	ECN 7224	12/16/03	HN																																		
SIZE	FSCM	DWG NO	REV	PLATING OPT.																																	
B	58167	26-1020-1410	L	A, B, C, D																																	
SCALE 2.5 : 1		F.S.R. #		SHEET 1 OF 1																																	