

4

3

2

1

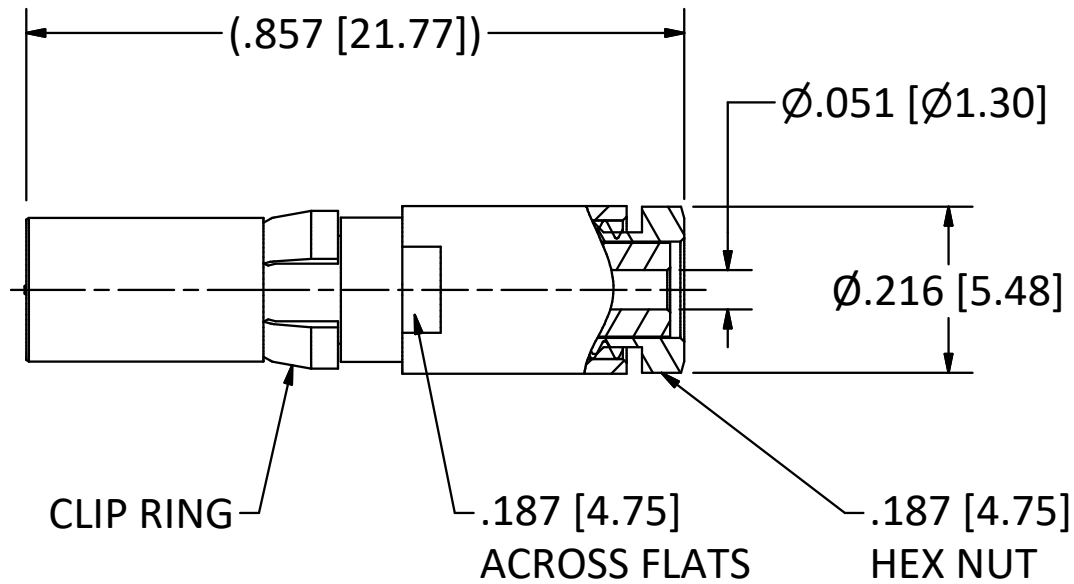
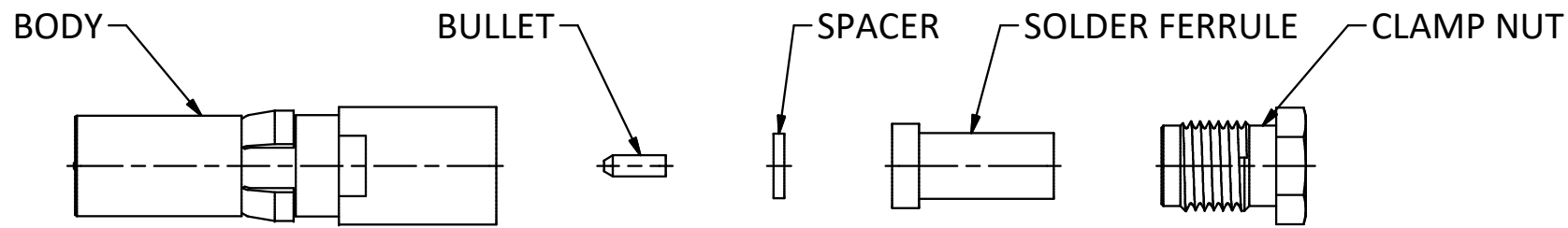

NOTES:

- 1. SPECIFICATIONS PER IDS-26.
 - 2. BULLET, CLAMP NUT, SPACER, AND SOLDER FERRULE SHIPPED LOOSE.
 - 3. ACCOMMODATES M17/151 (.047 SEMI-RIGID) OR EQUIVALENT FLEXIBLE CABLE.
- HOUSING:** D-SUBMINIATURE, SIZE 8 CAVITY.

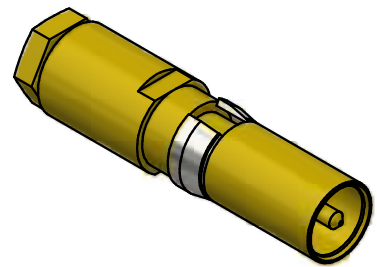

SCALE 2.5 : 1

| | | | |
|------|-------------|---------|-----|
| L | ECN 11014 | 6/27/11 | JEM |
| K | ECN 10498 | 8/5/10 | JEM |
| H | ECN 9738 | 1/08/09 | JEM |
| G | ECN 3995 | 7/28/97 | HN |
| REV. | DESCRIPTION | DATE | BY |

This drawing embodies a proprietary design of The Phoenix Company of Chicago, Inc., Naugatuck, CT 06770. All design, manufacturing, reproduction, use, sale, and other rights regarding the same are expressly reserved. The information in this drawing may be covered completely or in part by patents and/or patents pending.

WARNING - THIS DOCUMENT CONTAINS TECHNICAL DATA WHOSE EXPORT IS RESTRICTED BY THE ARMS EXPORT CONTROL ACT (TITLE 22, U.S.C., SEC 2751, ET. SEQ.) OR THE EXPORT ADMINISTRATION ACT OF 1979, AS AMENDED, TITLE 50, U.S.C., APP 2401 ET SEQ. VIOLATIONS OF THESE EXPORT LAWS ARE SUBJECT TO SEVERE CRIMINAL PENALTIES. DISSEMINATE IN ACCORDANCE WITH PROVISIONS OF DOD DIRECTIVE 5230.25.

Filename: ver2\Autodesk Inventor Data Base\Assemblies\26 Series\26-1030-0470-CU.idw

UNLESS OTHERWISE SPECIFIED, PHOENIX WORKMANSHIP STANDARDS APPLY DIMENSIONS IN INCHES OR (METRIC)

DO NOT SCALE PRINTS

TOLERANCES ARE:
FRACTIONS: ± 1/64
DECIMALS: .XX ± .01
.XXX ± .003
ANGLES: ± 1/2°

| APPROVALS | DATE |
|--------------|----------|
| DRAWN MS | 3/7/1991 |
| CHECKED PRP | 3/7/1991 |
| QA | |
| MFG | |
| ENGINEER MS | 3/7/1991 |
| APPROVED PRP | 3/7/1991 |

The PHOENIX Company of Chicago, Inc.

22 GREAT HILL RD., NAUGATUCK, CT 06770
WWW.PHOENIXOFCHICAGO.COM
PHONE: (800) 323-9562 FAX:(630) 206-1801

TITLE
PKZ® RECEPTACLE, SOLDER/CLAMP TERMINATION

| | | | | |
|---------------|------------|---------------------|-------|-------------------------|
| SIZE B | FSCM 58167 | DWG NO 26-1030-0470 | REV L | PLATING OPT. A, B, C, D |
| SCALE 2.5 : 1 | F.S.R. # | SHEET 1 OF 1 | | |

4

3

2

1