

4

3

2

1

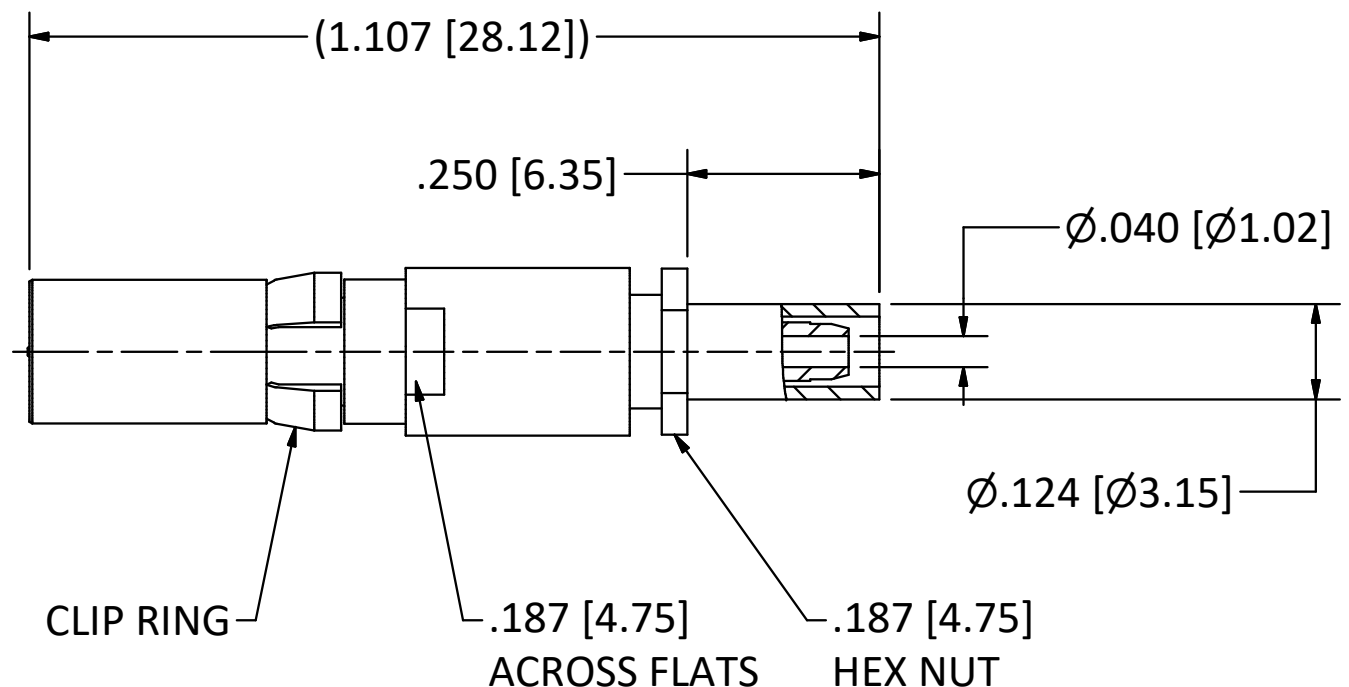
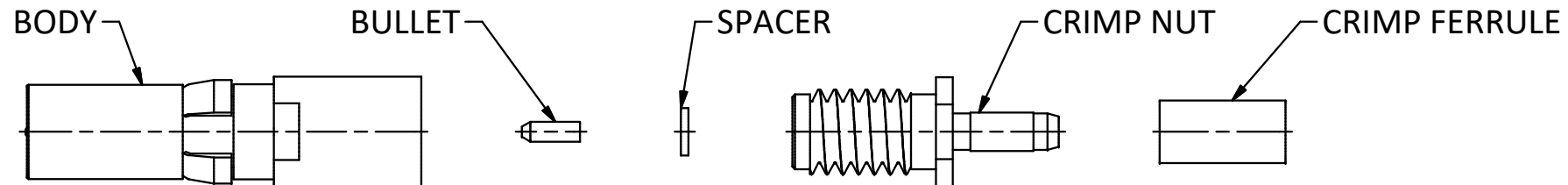

- NOTES:
- SPECIFICATIONS PER IDS-26.
  - CRIMP NUT, CRIMP FERRULE, BULLET, AND SPACER SHIPPED LOOSE.
  - ACCOMMODATES RG-178, RG-196, OR 1.37mm CABLE.
  - CRIMP USING .105 HEX DIE (22520/5-03).
- HOUSING:** D-SUBMINIATURE, SIZE 8 CAVITY.

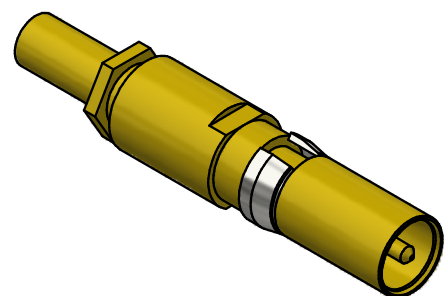

SCALE 2.5 : 1

<p>This drawing embodies a proprietary design of The Phoenix Company of Chicago, Inc., Naugatuck, CT 06770. All design, manufacturing, reproduction, use, sale, and other rights regarding the same are expressly reserved. The information in this drawing may be covered completely or in part by patents and/or patents pending.</p>				<p>WARNING - THIS DOCUMENT CONTAINS TECHNICAL DATA WHOSE EXPORT IS RESTRICTED BY THE ARMS EXPORT CONTROL ACT (TITLE 22, U.S.C., SEC 2751, ET. SEQ.) OR THE EXPORT ADMINISTRATION ACT OF 1979, AS AMENDED, TITLE 50, U.S.C., APP 2401 ET SEQ. VIOLATIONS OF THESE EXPORT LAWS ARE SUBJECT TO SEVERE CRIMINAL PENALTIES. DISSEMINATE IN ACCORDANCE WITH PROVISIONS OF DOD DIRECTIVE 5230.25.</p>		<p>Filename: ver2\Autodesk Inventor Data Base\Assemblies\26 Series\26-1080-0400-CU.idw</p>		<p><b>The PHOENIX Company of Chicago, Inc.</b>          22 GREAT HILL RD., NAUGATUCK, CT 06770          WWW.PHOENIXOFCHICAGO.COM          PHONE: (800) 323-9562 FAX:(630) 206-1801</p>													
						<p>UNLESS OTHERWISE SPECIFIED, PHOENIX WORKMANSHIP STANDARDS APPLY DIMENSIONS IN INCHES OR (METRIC)</p> <p>DO NOT SCALE PRINTS</p> <p>TOLERANCES ARE:          FRACTIONS: ± 1/64          DECIMALS: .XX ± .01          .XXX ± .003          ANGLES: ± 1/2°</p>				<table border="1"> <thead> <tr> <th>APPROVALS</th> <th>DATE</th> </tr> </thead> <tbody> <tr> <td>DRAWN EK</td> <td>11/16/2007</td> </tr> <tr> <td>CHECKED JEM</td> <td>11/16/2007</td> </tr> <tr> <td>QA</td> <td></td> </tr> <tr> <td>MFG</td> <td></td> </tr> <tr> <td>ENGINEER EK</td> <td>11/16/2007</td> </tr> <tr> <td>APPROVED EK</td> <td>11/16/2007</td> </tr> </tbody> </table>		APPROVALS	DATE	DRAWN EK	11/16/2007	CHECKED JEM	11/16/2007	QA		MFG	
APPROVALS	DATE																				
DRAWN EK	11/16/2007																				
CHECKED JEM	11/16/2007																				
QA																					
MFG																					
ENGINEER EK	11/16/2007																				
APPROVED EK	11/16/2007																				
<table border="1"> <thead> <tr> <th>REV.</th> <th>DESCRIPTION</th> <th>DATE</th> <th>BY</th> </tr> </thead> <tbody> <tr> <td>A</td> <td>ECN 9147</td> <td>11/16/07</td> <td>JEM</td> </tr> </tbody> </table>		REV.	DESCRIPTION	DATE	BY	A	ECN 9147	11/16/07	JEM	<table border="1"> <thead> <tr> <th>SIZE</th> <th>FSCM</th> <th>DWG NO</th> <th>REV</th> <th>PLATING OPT.</th> </tr> </thead> <tbody> <tr> <td>B</td> <td>58167</td> <td><b>26-1080-0400</b></td> <td>A</td> <td>A, B, C, D</td> </tr> </tbody> </table>		SIZE	FSCM	DWG NO	REV	PLATING OPT.	B	58167	<b>26-1080-0400</b>	A	A, B, C, D
REV.	DESCRIPTION	DATE	BY																		
A	ECN 9147	11/16/07	JEM																		
SIZE	FSCM	DWG NO	REV	PLATING OPT.																	
B	58167	<b>26-1080-0400</b>	A	A, B, C, D																	
<table border="1"> <thead> <tr> <th>SCALE</th> <th>F.S.R. #</th> <th>SHEET</th> <th>OF</th> </tr> </thead> <tbody> <tr> <td>2.5 : 1</td> <td></td> <td>1</td> <td>1</td> </tr> </tbody> </table>		SCALE	F.S.R. #	SHEET	OF	2.5 : 1		1	1												
SCALE	F.S.R. #	SHEET	OF																		
2.5 : 1		1	1																		

4

3

2

1